

# OPERATOR'S MANUAL

# **BIL-JAX**

A STEP ABOVE®

---

3522A  
133/70A

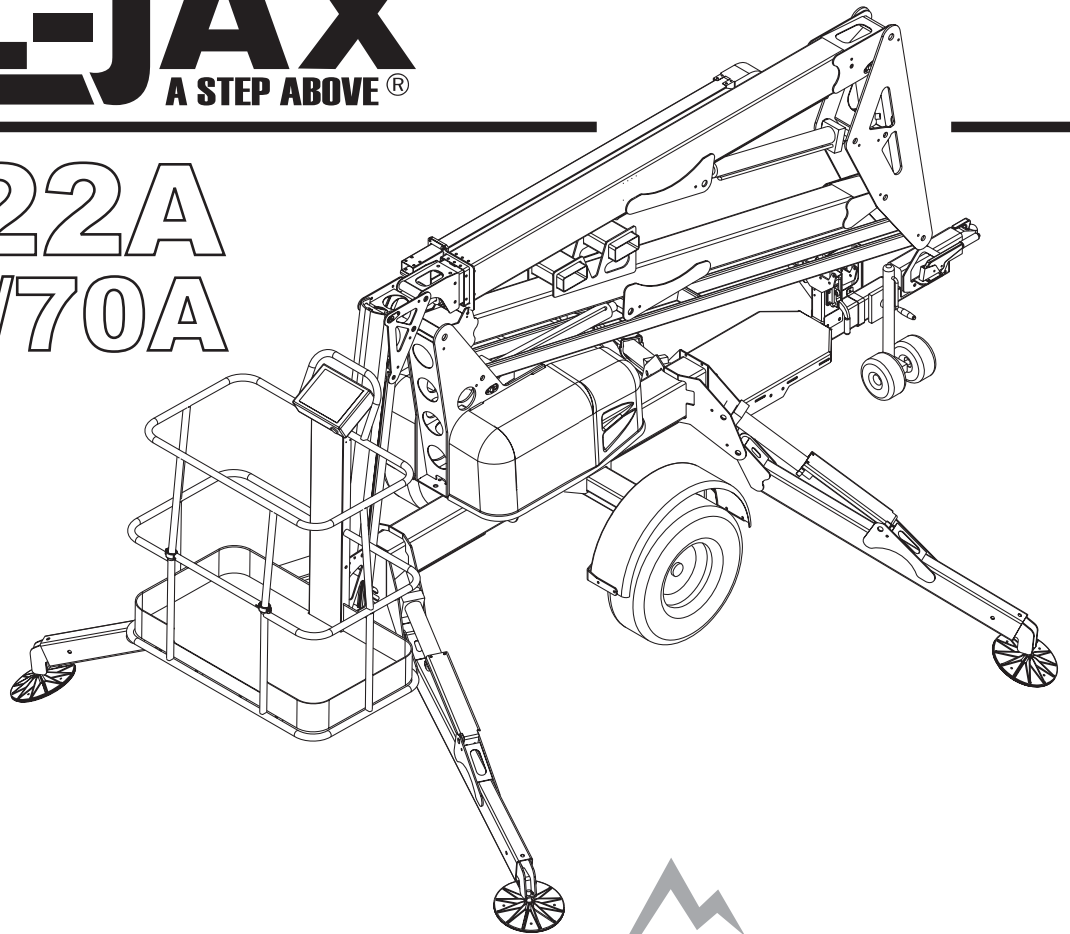

---

**SUMMIT**SERIES  
TRAILER-MOUNTED BOOMS™

---

## BOOM PERSONNEL LIFT

This equipment is designed and manufactured in compliance with the duties, responsibilities and standards set forth in the ANSI, CE CSA and/or AS standards in effect at the time of manufacture.

**This equipment will meet or exceed applicable ANSI, CE, CSA and/or AS codes and standards when operated in accordance with manufacturer's recommendations.**

It is the responsibility of the user to follow all regional codes and regulations that govern the safe operation of this equipment.

**Obtain, read and obey all safety precautions before performing maintenance or repairs or attempting to operate this equipment.** This includes all manufacturer recommendations as well as those directives set forth by government and local authorities.

To ensure proper and safe use of this equipment, it is strongly recommended that only trained and authorized personnel attempt to operate and maintain the boom lift.

This manual shall be considered a permanent and necessary component of the machine and shall be kept with the boom lift at all times.

Owners and Lessors should complete a full inspection of all components and perform a test of all functions, including brake functions, before commissioning or reselling the machine. Repair or replace all damaged or malfunctioning components.

---

Bil-Jax, Inc. is dedicated to the continuous improvement of this and all Bil-Jax products. Therefore, equipment information is subject to change without notice. Direct any questions or concerns regarding errors or discrepancies in this manual to the Bil-Jax Service Department.

---

**Copyright © Bil-Jax, Inc. 2007. All Rights Reserved.**

"Bil-Jax" is a registered trademark and "A Step Above" and "Summit Series" are trademarks of Bil-Jax, Inc. Contact Bil-Jax for replacement manuals.



125 Taylor Parkway  
Archbold, Ohio 43502

Phone (800) 537-0540  
(419) 445-8915  
Fax (419) 445-0367

# TABLE OF CONTENTS

---

<b>Table of Contents</b>	<b>1</b>
<b>Illustrations</b>	<b>2</b>
<b>Tables</b>	<b>2</b>
<b>1 Safety</b>	<b>3</b>
Legend: Safety Advisories	4
Before Operation	5
During Operation	5
Maintenance Safety	7
Damaged Equipment Policy	8
<b>2 Specifications</b>	<b>9</b>
Range of Motion	10
Specifications	11
Warranty	12
<b>3 Operations</b>	<b>13</b>
Ground Control Station	14
Platform Control Station	16
Normal Operating Procedure	18
Manual Boom Operations	20
Battery Recharge	22
Boom Lift Transport	23
<b>4 Operator Service</b>	<b>25</b>
Daily Service Checks	26
Weekly Service Checks	28
Monthly Service Checks	29
Troubleshooting	30
Error Code Definitions	31
<b>5 Replacement Decals</b>	<b>35</b>
<b>6 ANSI Reprint</b>	<b>39</b>
<b>7 Material Safety Data</b>	<b>45</b>
<b>8 Equipment Options</b>	<b>49</b>
Material Lifting Hook	50
Platform Rotator	51
Drive and Set	52
Replacement Decals	55
<b>Service Checklists</b>	<b>56</b>

# LIST OF ILLUSTRATIONS

---

Figure 2-1	Range of Motion	10
Figure 3-1	Ground Control Panel	14
Figure 3-2	Platform Control Panel	16
Figure 3-3	Outrigger Controls	18
Figure 3-4	Boom Travel Latch	18
Figure 3-5	Hand Pump and Controls for Manual Operation	20
Figure 3-6	Manual Lowering Valve	21
Figure 3-7	Battery Charger Faceplate	22
Figure 3-8	Trailer Hitching	23
Figure 3-9	Boom Lift and Transport Instructions	24
Figure 4-1	Outrigger Position Switches	26
Figure 4-2	Hydraulic Reservoir	27
Figure 4-3	Wheel Nut Tightening Sequence	29
Figure 5-1	Decal Placements	37
Figure 6-1	Minimum Safe Approach Distances	43
Figure 8-1	Material Lifting Hook Configuration	50
Figure 8-2	Material Lifting Hook Installation	50
Figure 8-3	Manual Platform Rotator	51
Figure 8-4	Jockey Wheel Instruction	52
Figure 8-5	Drive and Set Controls	53
Figure 8-6	Material Lift Decal Placement	55
Figure 8-7	Optional Components Decal Placement	55

# LIST OF TABLES

---

Table 1-1	Minimum Safe Approach Distances	4
Table 3-1	Charger Fault Codes	22
Table 4-1	Troubleshooting Steps	30
Table 4-2	Error Code Definitions	31
Table 5-1	Replacement Decal Descriptions	36
Table 8-1	Replacement Decals – Optional Components	55

# 1 SAFETY

---

Proper training is required for the safe operation of any mechanical device. Failure to follow all instructions and safety precautions in this manual and attached to the lift will result in death or personal injury.

**Prior to Operation:**

- Read, understand and obey all instructions and safety precautions in this manual and attached to the lift.
- Read, understand and obey all applicable government regulations.
- Become familiar with the proper use of all controls.
- Inexperienced users should receive instruction before attempting to operate or maintain the machine.

The use of intelligence and common sense is the best practice when following any safety policy.

**LEGEND: SAFETY ADVISORIES**

The following safety advisories are used throughout this manual to indicate specific hazards when operating or maintaining the machine. Read, understand and obey all safety advisories to prevent improper service, damage to equipment, personal injury or death.

 **DANGER** \_\_\_\_\_

**Warns of operation near electrical power sources that could lead to personal injury or death.**

---

 **WARNING** \_\_\_\_\_

**Describes conditions or practices that could lead to personal injury or death.**

---

 **CAUTION** \_\_\_\_\_

**Contains information important in the prevention of errors that could damage machine or components.**

---

**NOTE: Contains additional information important for performing a procedure.**

## BEFORE OPERATION

Ensure the following general safety precautions are followed before operating the telescoping boom lift:

ALWAYS inspect the usage area for potential hazards, such as unstable or unlevel surfaces, overhead obstructions and electrically charged wires or conductors. ALWAYS watch for moving vehicles in the operating area.

ALWAYS conduct a thorough inspection of the machine before operation. Check for damaged or worn parts, hydraulic leaks, damaged wiring, loose wiring conductors, damaged outriggers, low tire pressure, uneven tire wear or tire damage. Check for any improperly operating components. NEVER operate equipment if any damage is observed or suspected. Repair damaged or malfunctioning equipment before operation.

ALWAYS wear proper clothing. Wear protective equipment as required by government regulations. Keep loose clothing, jewelry, gloves and hair away from moving parts.

ALWAYS wear a safety harness and energy-absorbing lanyard, such as the safety harness and lanyard provided by Bil-Jax.

ALWAYS inspect platform floor and outrigger footpads for mud, grease, debris or other foreign material. ALWAYS remove any such material from the equipment before operation.

ALWAYS tag any part of the equipment known or suspected to be damaged or malfunctioning. ALWAYS remove a malfunctioning, damaged or defective machine from service. NEVER operate a machine that has any known or suspected defect.

ALWAYS comply with the instructions found in Safety and/or Service Bulletins distributed by the manufacturer. Bulletins may contain critical procedures that supersede the information contained in manuals.

NEVER operate this equipment while under the influence of drugs or alcohol, while taking prescription medications that may leave the operator drowsy or prone to dizziness, or while feeling ill.

NEVER modify, alter or change the equipment in any way that would affect its original design or operation.

NEVER deface, modify or obscure any decals or markings on equipment.

NEVER operate the equipment in any way for which it is not intended.

## DURING OPERATION

Ensure the following general safety precautions are followed while operating the telescoping boom lift:

ALWAYS position lift away from power lines to ensure that no part of the lift can accidentally reach into an unsafe area. This includes full extension of the boom through 700° rotation.



**This machine is NOT insulated for use near electrical power lines and DOES NOT provide protection from contact with or close proximity to any electrically charged conductor. Operator must maintain safe clearances at all times (3.05 meters minimum) and must always allow for platform movement due to gusty winds. Always contact power company before working near power lines. Assume every power line is live. Power lines can be blown by the wind. Refer to Table 1-1 for minimum safe approach distances between the machine and electrical power lines.**

Voltage Range (Phase to Phase)	Minimum Safe Approach Distance	
	(Feet)	(Meters)
0 to 300V	Avoid Contact	
Over 300V to 50KV	10	3.05
Over 50KV to 200KV	15	4.60
Over 200KV to 350KV	20	6.10
Over 350KV to 500KV	25	7.62
Over 500KV to 750KV	35	10.67
Over 750KV to 1000KV	45	13.72

**Table 1-1. Minimum Safe Approach Distances**

ALWAYS keep away from a machine that is exposed to energized power lines. If the machine contacts energized power lines, NEVER touch or operate the machine until power lines are shut off.

ALWAYS operate only on a firm and level surface. NEVER operate on surfaces that do not support the equipment with its rated load capacity or on surfaces that do not support force exerted by the outriggers during boom operation. Operate only on surfaces that can support a pressure of 1.8 kg/cm<sup>2</sup> (25 psi) to ensure safe operation.

ALWAYS keep personnel away from potential pinch and shear points and from potential crush hazards as indicated by decals attached to the machine.

ALWAYS maintain sure footing on the work platform.

ALWAYS keep the safety bar lowered unless personnel are entering or exiting the work platform.

ALWAYS wear proper footgear. ALWAYS keep the platform free of debris.

ALWAYS keep personnel and obstructions clear of the machine when repositioning boom or basket.

ALWAYS cordon the area surrounding the outriggers to keep personnel, vehicles and moving equipment away from the machine while in use.

ALWAYS stay clear of overhead obstructions, including wires and cables.

ALWAYS engage boom travel latches before towing trailer.

ALWAYS exercise caution when rotating the boom (slew) from the ground control station. ALWAYS watch for personnel inside the radius of the turntable and boom arm when rotating the boom lift from the ground or platform controls.

ALWAYS remove personnel from the boom lift before attempting to free an elevated platform that has become caught or snagged on an adjacent structure or obstacle.

NEVER operate the machine on any surface other than firm and level ground. NEVER operate the machine from a position on truckbeds, trailers, floating vessels or scaffolding without written approval from the manufacturer.

NEVER operate lift on slopes exceeding 12.5°.

NEVER allow electrode contact with any part of the machine while welding from the platform. NEVER use the machine as a ground for welding.

NEVER operate without the outriggers fully extended or when the machine is not level.

NEVER position an elevated platform against another object to steady the platform

NEVER override or bypass the manufacturer's safety devices.

NEVER attach a safety harness to an adjacent structure, pole, or to nearby equipment while working from the boom platform.

NEVER raise the outriggers or move the trailer with materials or personnel on board, or while boom is raised or extended.

NEVER sit, stand or climb on cage bars. ALWAYS keep both feet firmly on the work cage floor when working from an elevated platform.

NEVER attempt to increase the working height with boxes, ladders, stools or any other materials.

NEVER operate this equipment when exposed to high winds, thunderstorms, ice or any weather conditions that would compromise operator safety.

NEVER operate boom lift in conditions where wind speeds exceed 12.5 m/sec (45 km/h or 28 mph). Steady or gusty winds that exceed 12.5 m/sec (45 km/h) may affect stability and boom operation.

NEVER allow ropes, electric cords, hoses or other equipment to become entangled in the machine while raising or lowering platform.

NEVER exceed the load limits set by the manufacturer. Use only the Material Lifting Hook, supplied as an option and manufactured by Bil-Jax, when lifting materials. Safely stow all tools and equipment.

NEVER exceed load ratings by transferring loads to the lift at elevated heights.

NEVER use the platform to lift a load that exceeds the platform dimensions. NEVER lift a load in such a way that the center of gravity is higher than the top guardrail of the platform.

NEVER modify the platform or carry materials that would increase the surface area of the platform. Increasing the area exposed to the wind may decrease machine stability. NEVER attach overhanging loads when raising or lowering the platform.

NEVER use the boom or platform to push or pull or to lift any part of the trailer.

NEVER use the boom or platform to place a load against any structure, materials or equipment.

NEVER climb on the boom. Refer to Section 3 for the instructions for manual operation.

NEVER leave an elevated platform unattended.

NEVER leave the keys in the boom lift while unattended or not in use.

## MAINTENANCE SAFETY

Ensure the following general safety precautions are followed while performing maintenance on the telescoping boom lift:

### General Maintenance

ALWAYS perform maintenance procedures according to manufacturer's guidelines. NEVER disregard or bypass proper maintenance procedures.

ALWAYS inspect hydraulic system to ensure that all lines, connectors and fittings are properly fastened and in good condition.

ALWAYS turn the key switch OFF and remove key before performing maintenance.

Whenever possible, ALWAYS perform maintenance with the boom and platform in a fully lowered, stowed position. ALWAYS secure the boom before performing maintenance on hydraulic cylinders.

ALWAYS disconnect power to the hydraulic pump drive motor before making electrical checks to the hydraulic valves.

ALWAYS keep all mechanical parts properly adjusted and lubricated according to maintenance schedule and manufacturer's specifications.

ALWAYS perform a function check of operating controls before each use and after repairs have been made.

ALWAYS locate and protect against possible pinch points before performing any maintenance or repairs.

ALWAYS use only manufacturer-approved parts to repair or maintain equipment. If any portion of this equipment is rebuilt or repaired, retesting is required in accordance with factory instructions.

ALWAYS maintain a safe distance while testing the hydraulic components. ALWAYS relieve hydraulic pressure before loosening or removing hydraulic components. NEVER test or operate the hydraulic components while personnel are near the equipment.

NEVER allow water or foreign particles into the DC electric motor housing. Inclusion of water or foreign particles may cause serious damage to the motor. If the motor becomes wet, consult an authorized Bil-Jax service technician for proper drying instructions.

NEVER add unauthorized fluids to the hydraulic system or battery. NEVER mix hydraulic oils. Consult manufacturer specifications. Refer to Section 4 for hydraulic system maintenance procedures.

NEVER exceed the manufacturer's recommended relief valve settings.

NEVER touch or allow metal tools to contact any components that are sensitive to static discharge. ALWAYS use static discharge prevention mats and grounding devices when handling electronic components.

NEVER adjust, repair, replace or bypass any hydraulic or electrical control or safety device. These include, but are not limited to, hydraulic load control and flow control valves, solenoid valves and limit switches. ALWAYS consult an authorized Bil-Jax technician if repairs are necessary.

NEVER modify, alter or change the equipment without first consulting an authorized Bil-Jax technician, and NEVER in any way that would affect its original design or operation.

### Battery Maintenance

Ensure the following general safety precautions are followed when performing battery maintenance on the telescoping boom lift.

ALWAYS check the battery fluid level daily.

ALWAYS wear safety glasses when working with or near batteries.

ALWAYS avoid contact with battery acid. Battery acid causes serious burns and should be kept away from skin or eyes. If contact occurs, flush with water and consult a physician immediately.

ALWAYS disconnect ground cable first when removing battery.

ALWAYS connect ground cable last when installing battery.

ALWAYS charge batteries in open, well-ventilated areas.

ALWAYS replace batteries using only parts recommended by manufacturer. ALWAYS use only batteries with sealed caps over cells.

NEVER smoke while servicing batteries.

NEVER charge batteries near flammable materials.

NEVER allow batteries to overcharge and boil.

NEVER short across battery posts to check for current. NEVER break a live circuit at the battery.

NEVER disconnect battery from charger while charger is connected to a live power source.

NEVER jumpstart other vehicles using the boom lift batteries.

## **DAMAGED EQUIPMENT POLICY**

### **Safety Statement**

At Bil-Jax, we are dedicated to the safety of all users of our products. All Bil-Jax lifts are designed, manufactured and tested to comply with current applicable ANSI and/or CE codes and regulations.

### **Damage Policy**

There may be occasions when a Bil-Jax lift is involved in an incident that results in structural damage to the lift. Such damage can seriously compromise the ability of the lift to perform in a safe manner. Therefore, whenever a Bil-Jax lift is damaged structurally or when there is suspected internal damage to the structure, Bil-Jax may require that the lift be returned to our facility for reconditioning. For any questions concerning structural damage or the Damaged Equipment Policy, please contact an authorized Bil-Jax representative or your regional Bil-Jax dealer

### **Damage Repair Notice**

There may be occasions when a Bil-Jax lift is involved in an accident resulting in damage to non-structural components. When such damage occurs and repairs are made by the owner or area distributor, please notify Bil-Jax of these non-maintenance repairs and request a repair form to be filled out and returned to Bil-Jax.

# 2 SPECIFICATIONS

---

Bil-Jax, Inc. is dedicated to the continuous improvement of this and all Bil-Jax products. Therefore, equipment information is subject to change without notice.

The following information is based on ideal working conditions. Machine performance may vary based on work environment and on machine options.

Direct any questions or concerns regarding equipment specifications to your regional Bil-Jax representative or to the Bil-Jax Service Department.

# RANGE OF MOTION

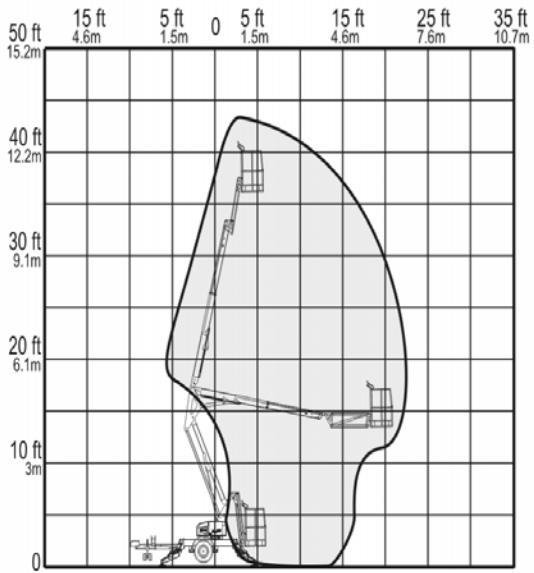

Figure 2-1. Range of Motion

# SPECIFICATIONS

SERIAL NUMBER \_\_\_\_\_

<b>Working Height</b>	43 ft 2 in 13.3 m
<b>Maximum Platform Height</b>	37 ft 2 in 11.3 m
<b>Maximum Horizontal Outreach</b>	
From Centerline	22 ft 6 in 6.9 m
From Outrigger Footpad Edge	17 ft 6 in 5.3 m
<b>Rated Platform Capacity</b>	
Without Platform Rotation	500 lbs 227 kg
With Platform Rotation	440 lbs 200 kg
<b>Maximum Occupants</b>	2
<b>Tongue Weight</b>	190 lbs 86 kg
<b>Total Weight</b>	3,080 lbs 1397 kg
<b>Turntable Rotation</b>	700° Non-Continuous
<b>Leveling Capability</b>	12.5°
<b>Platform Dimensions</b>	
Height	3 ft 7 in 1.1 m
Length	2 ft 6 in 0.8 m
Width	4 ft 1.2 m
<b>Stowed Dimensions</b>	
Height	6 ft 5 in 2.0 m
Length	16 ft 3 in 5.0 m
Width	5 ft 6 in 1.7 m
<b>Outrigger Footprint</b>	
Length	11 ft 1 in 3.4 m
Width	9 ft 11 in 3.0 m
Footpad Diameter	10 in 0.3 m
<b>Parking Brake</b>	Standard, Mechanical

<b>Towing Brake</b>	Mechanical Surge
<b>Rated Towing Speed</b>	65 mph 105 km/h
<b>Tire Size</b>	ST 205/75 R14C
<b>Control System</b>	24V DC
<b>Battery</b>	4 x 6V 245 amp-hr
<b>Charger</b>	
Standard	110/120 Volt
CE	220 Volt
<b>Hydraulic Pressure</b>	3,000 psi 206 bar
<b>Reservoir Capacity</b>	3.1 Gallons 11.7 L
<b>Hydraulic System Capacity</b>	5.1 Gallons 19.3 L
<b>Hydraulic Oil (Standard)</b>	Dexron III/Mercon ATF
<b>Platform Rotation/Type (Optional)</b>	90°/Manual
<b>Maximum Decibel Level</b>	
Standard DC Mode – Ground	60 dB
Standard DC Mode – Platform	55 dB
DC/Gas Option – Ground	70 dB
DC/Gas Option - Platform	65 dB
<b>Function Speeds</b>	
Boom Raise (Fast)	30-35 Seconds
Boom Raise (Slow)	50-55 Seconds
Boom Lower (Fast)	45-50 Seconds
Boom Lower (Slow)	120-150 Seconds
Boom Extend (Fast)	30-35 Seconds
Boom Extend (Slow)	75-90 Seconds
Boom Retract (Fast)	40-45 Seconds
Boom Retract (Slow)	100-110 Seconds
Turntable Rotation (Fast)	82-90 Seconds
Turntable Rotation (Slow)	240-270 Seconds
Platform Level (Fast)	8-10 Seconds
Platform Level (Slow)	12-16 Seconds
Outrigger Extend	15-20 Seconds
Outrigger Retract	25-30 Seconds
<b>Localized Pressure per Outrigger</b>	25 psi 1.8 kg/cm <sup>2</sup> 176.5 kPa
<b>Operation Temperature Range</b>	-20° to 110° Fahrenheit -29° to 43° Celsius

## **WARRANTY**

Bil-Jax, Inc. warrants this product for one year, beginning on the date of delivery, to be free from defects of material and workmanship provided the unit is operated and maintained in compliance with the guidelines established in the Operations and Maintenance Manuals. Major structural components, including trailer tongue and boom weldments, are warranted for five years against defects due to material or workmanship. Bil-Jax will, at its option, repair or replace any unit or component part that fails to function properly during normal use.

The warranty does not apply if the lift and/or its components have been altered, changed, or repaired without the consent of Bil-Jax. Repairs, damage, or defects resulting from the following are not covered under the terms of the warranty: negligence, misuse, accidental damage, inadequate or improper maintenance, acts of nature, damage caused by chemicals or abrasive materials, and normal wear and tear, such as rust or corrosion. Components not covered under this warranty include tires, filters, covers, and routine maintenance items. Components not manufactured by Bil-Jax are covered by their respective manufacturer's warranties. A list of those components and their warranties is available upon written request to Bil-Jax.

Bil-Jax shall not in any event be liable for the cost of any special, indirect, or consequential damages to any person, product, or thing. Bil-Jax's maximum liability under this warranty is limited to the amount paid to Bil-Jax for the product. This warranty is in lieu of all other warranties expressed or implied. Bil-Jax neither assumes nor authorizes any or other entity to assume on its behalf any other liability in connection with the sale, rental, or use of this product.

### **Warranty Claims Process**

In order to qualify for warranty coverage, the following conditions must be met:

1. Return of completed "Warranty Registration" form to Bil-Jax within 15 days of receipt of product;
2. Notification to Bil-Jax within 72 hours of any claimed defect, injury, or damage resulting from the claimed defect; and
3. Warranty is limited to parts that are determined to be defective. This does not include parts worn out due to normal use.
4. Bil-Jax authorized dealers or distributors are responsible for filing claims under warranty. Listed below is the warranty claims procedure.
5. Contact Bil-Jax Service Department at 800-537-0540 to report the claim and verify warranty coverage. Machine serial number must be provided.
6. Identify the components to be claimed under warranty along with description of failure. A Returned Merchandise Authorization (RMA) number will be issued by Bil-Jax.
7. Replacement parts will then be sent by Bil-Jax to the dealer or distributor. All parts are invoiced at dealer/distributor list price. Credits will be issued when defective parts are returned to Bil-Jax and found to be defective under warranty.
8. After completing repairs, submit warranty claim form and defective parts to Bil-Jax. Warranty claim form and parts must be received within 30 days of claim in order to be eligible for credit. RMA number must be referenced on warranty claim form. Returned parts are to be sent prepaid and will be credited when part is received and verified. Warranty labor rate will be paid at current rate set by Bil-Jax. The amount of labor hours reimbursed will be determined by Bil-Jax and will be limited to 4 hours unless approved by Bil-Jax.

Failure to follow the warranty claims process may result in delay in processing claim or denial of the claim. Bil-Jax reserves the right to limit or adjust warranty claims with regard to parts, labor and travel time. Components purchased from suppliers other than Bil-Jax are not covered under the terms of this warranty.

# 3 OPERATION

---

The Bil-Jax Telescoping Boom Lift is equipped with multiple operator control stations. Equipment power and outrigger controls are located at ground level. Boom lift and rotation controls are located at ground level and on the work platform.

Before attempting boom lift operation, Operators should:

- ❑ Attend a training program as required by government regulations.
- ❑ Obtain, read and obey all safety precautions as indicated by manufacturer's recommendations and all federal, state and local regulations.
- ❑ Become familiar with the location and use of all controls.
- ❑ Verify that there are no overhead obstructions or live power sources in the work area that could interfere with the safe operation of the boom lift.
- ❑ Position the boom lift on a firm and level surface.
- ❑ Conduct a Pre-Operation inspection by performing all recommended Daily Service Checks. Refer to Section 4.
- ❑ Unhitch equipment trailer from the tow vehicle.

## GROUND CONTROL STATION

The ground control station is used to operate outriggers and control boom motion. To access the ground control station, open the control panel access cover found on the turntable. Turn the key switch to the ground controls setting.

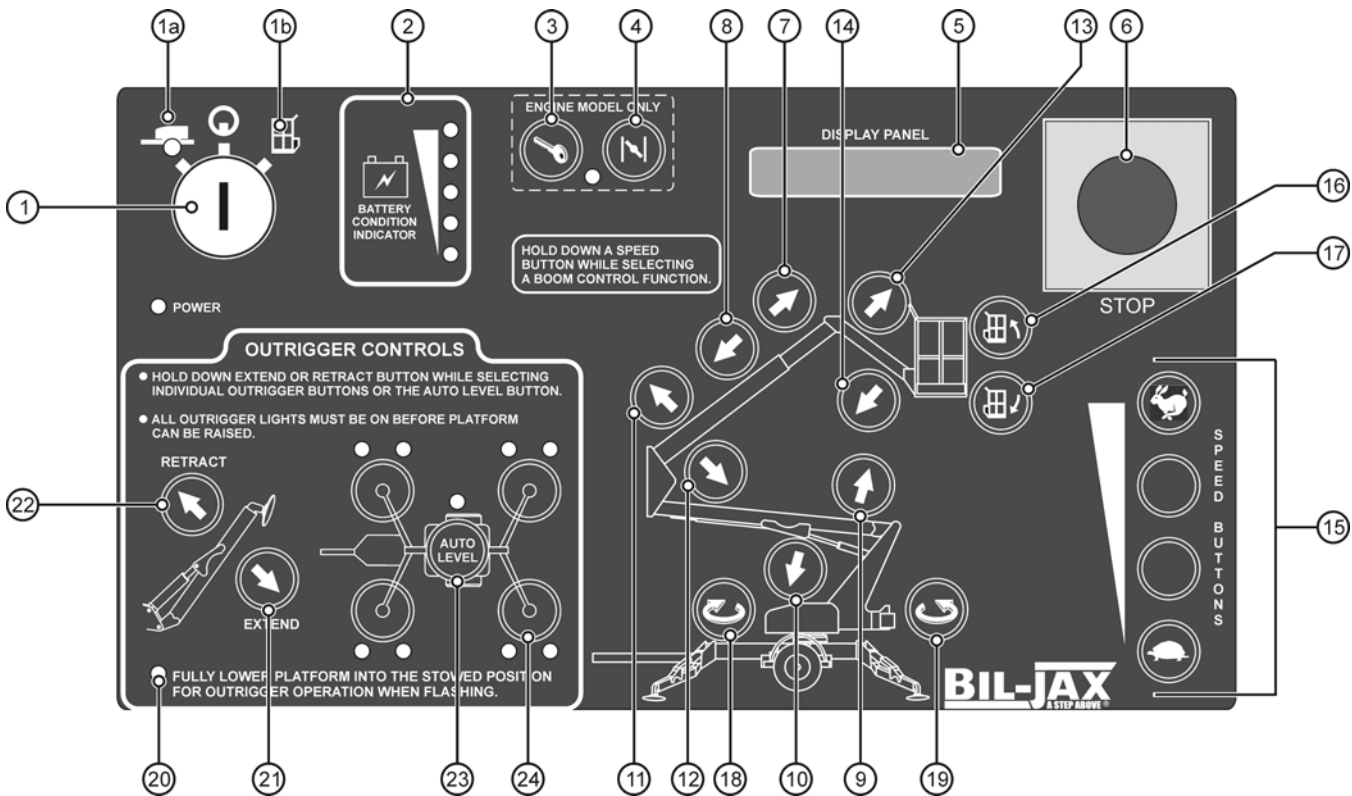

Figure 3-1. Ground Control Panel

- |                                |                                      |
|--------------------------------|--------------------------------------|
| 1. Key Switch                  | 12. Upper Boom Down                  |
| 1a. Ground Controls Position   | 13. Jib Raise                        |
| 1b. Platform Controls Position | 14. Jib Down                         |
| 2. Battery Condition Indicator | 15. Speed Buttons                    |
| 3. Engine Start                | 16. Platform Tilt – Up               |
| 4. Engine Choke                | 17. Platform Tilt – Down             |
| 5. Display Panel               | 18. Boom Rotation – Clockwise        |
| 6. Emergency Stop              | 19. Boom Rotation – Counterclockwise |
| 7. Boom Extend                 | 20. Outrigger Status Indicator LED   |
| 8. Boom Retract                | 21. Outrigger Extend                 |
| 9. Lower Boom Raise            | 22. Outrigger Retract                |
| 10. Lower Boom Down            | 23. Auto Level                       |
| 11. Upper Boom Raise           | 24. Outrigger Button                 |

The ground control station includes the following controls and Indicators. Refer to Figure 3-1 for control locations.

### **1. Key Switch**

Turning the key switch to the PLATFORM (1A) icon selects operation from the platform. Turning the key switch to the GROUND (1B) icon selects operation from the ground control panel. The center (power off) position interrupts all electric and hydraulic power operations except emergency lowering. Removing the key protects against operation by unauthorized persons. The key may be removed with the key switch in any selected position.

### **2. Battery Condition Indicator**

Indicator LEDs light up to indicate the level of charge remaining in the batteries. A lighted green LED indicates an adequate charge level. Lighted yellow LEDs indicate the need for charging soon. A lighted red LED warns that the battery charge level is low; boom operations should be halted until the batteries are recharged.

### **3-4. Engine Start and Choke**

Start a cold engine by pressing the Engine START button while pressing and holding the CHOKE button. To start/restart a warm engine, press the START button only.

### **5. Display Panel**

The DISPLAY PANEL is a lighted text window that displays the present operating status or an existing error condition when the key switch is on.

### **6. Emergency Stop Button**

When pushed in, the emergency STOP button disconnects electrical power to the ground and platform control stations. The emergency STOP pushbutton should only be pressed to immediately stop all boom motion. To resume control, pull out the emergency STOP button.

### **7-8. Boom Extend/Retract Buttons**

Pressing and holding a desired SPEED button and the BOOM EXTEND button at the same time extends the telescopic boom. Pressing and holding a desired SPEED button and the BOOM RETRACT button at the same time retracts the boom. Boom motion continues until the buttons are released or until the boom reaches a hard stop or a safe travel limit.

### **9-14. Boom Raise/Down Buttons**

Pressing and holding a desired SPEED button and the UPPER/LOWER/JIB BOOM RAISE button at the same time will raise the chosen boom. Pressing a desired SPEED button and the UPPER/LOWER/JIB BOOM DOWN button at the same time will lower the chosen boom. Boom motion continues until the buttons are released or until the boom reaches a hard stop or a safe travel limit.

### **15. Speed Buttons**

The SPEED buttons along the lower right side of the control panel must be pressed and held while selecting a boom function. Four speeds are available to control the positioning of the boom lift.

### **16-17. Platform Tilt Buttons**

Press and hold any SPEED button and the desired PLATFORM TILT button at the same time to level the work platform (levels the platform only, not the boom lift).

### **18-19. Boom Rotation Buttons**

Pressing and holding a desired SPEED button and the BOOM ROTATION CLOCKWISE or COUNTERCLOCKWISE button at the same time enables the boom to rotate in the direction selected. The boom will rotate through 700 degrees until the buttons are released or the stop is reached.

### **20-24. Outrigger Controls**

For automatic outrigger extension/retraction: Select EXTEND or RETRACT outrigger button and the AUTO LEVEL button at the same time. To manually extend or retract the outriggers: Select EXTEND or RETRACT outrigger button and one of the OUTRIGGER buttons at the same time. The outrigger indicator LEDs light up when the outriggers are properly deployed and the boom weight is on the outriggers. Each of the outer outrigger LEDs indicates load is on the outrigger footpad. Each of the inner outrigger LEDs, when flashing, indicate that side is low and needs to be further raised for leveling. The Auto Level LED lights up and a buzzer sounds when the boom is level.

## PLATFORM CONTROL STATION

The platform control station is used to control boom motion. To access the platform control station, turn the key switch at the ground control station to the platform controls setting and enter the work cage.

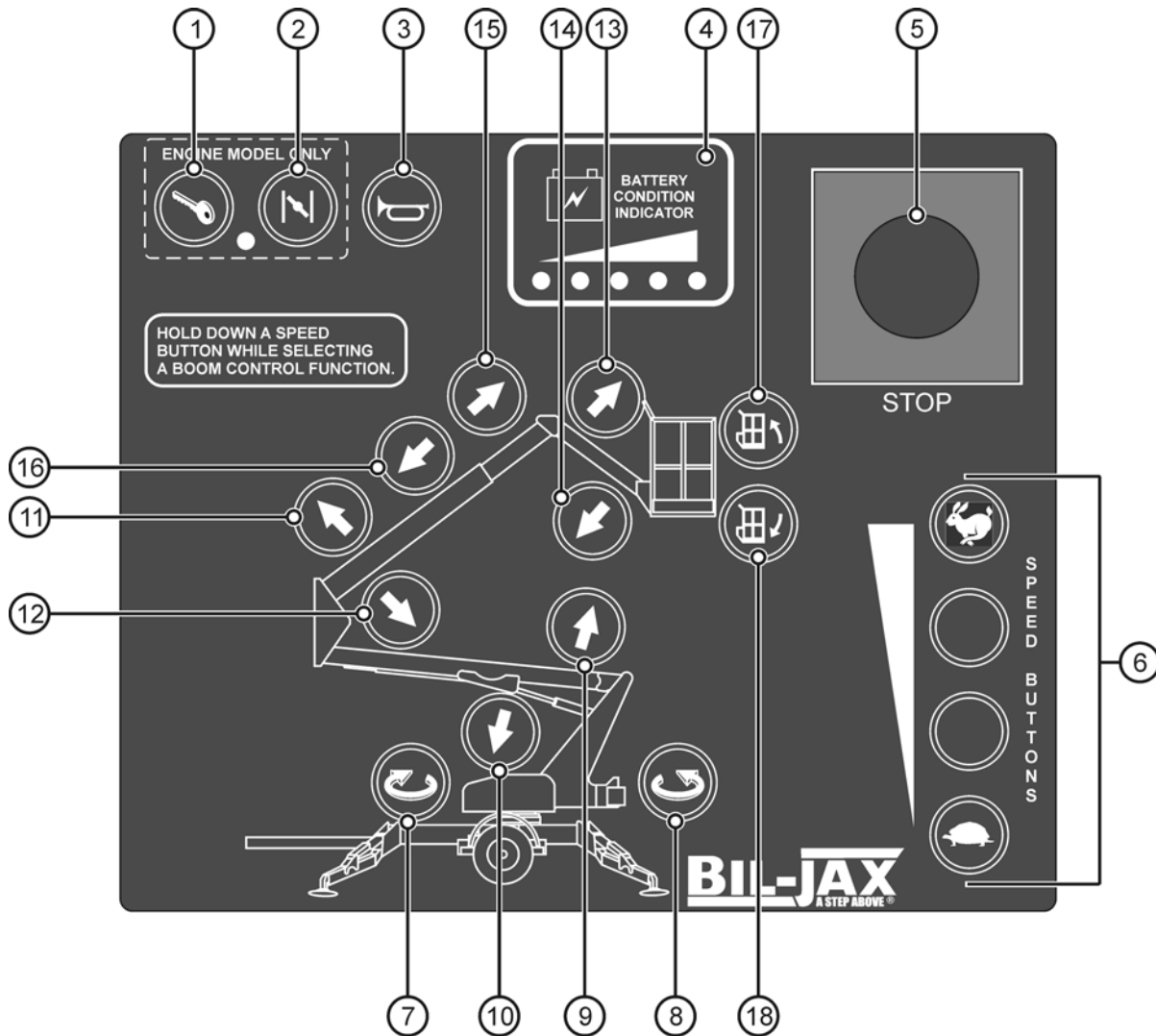

Figure 3-2. Ground Control Panel

- |                                     |                          |
|-------------------------------------|--------------------------|
| 1. Engine Start (DC/Gas Model Only) | 10. Lower Boom Down      |
| 2. Engine Choke (DC/Gas Model Only) | 11. Upper Boom Raise     |
| 3. Horn Button                      | 12. Upper Boom Down      |
| 4. Battery Condition Indicator      | 13. Jib Boom Raise       |
| 5. Emergency Stop Button            | 14. Jib Boom Down        |
| 6. Speed Buttons                    | 15. Boom Extend          |
| 7. Boom Rotation – Clockwise        | 16. Boom Retract         |
| 8. Boom Rotation – Counterclockwise | 17. Platform Tilt – Up   |
| 9. Lower Boom Raise                 | 18. Platform Tilt – Down |

The platform control station includes the following controls and Indicators. Refer to Figure 3-2 for control locations.

### **1-2. Engine Start and Choke (DC/Gas Model only)**

Start a cold engine by pressing the CHOKE button, then press the engine START button to start the engine. To start/restart a warm engine, press the START button only.

### **3. Horn Button**

Pressing the button will sound the horn. Use the HORN button to warn personnel in the area of a falling object hazard, impending boom motions, or the need for assistance.

### **4. Battery Condition Indicator**

Indicator LEDs light up to indicate the level of charge remaining in the batteries. A lighted green LED indicates a good charge level. Lighted yellow LEDs indicate the need for charging soon. A lighted red LED warns that the battery charge level is low; boom operations should be halted until the batteries are recharged.

### **5. Emergency Stop Button**

When pushed in, the emergency STOP button disconnects electrical power to the ground and platform control stations. The emergency STOP pushbutton should only be pressed to immediately stop all boom motion. To resume control, pull out the emergency STOP button.

### **6. Speed Buttons**

The SPEED buttons along the lower right side of the control panel must be pressed and held while selecting boom functions. Four speeds are available to control the positioning of the boom lift.

### **7-8. Boom Rotation Buttons**

Pressing and holding a desired SPEED button and the BOOM ROTATION CLOCKWISE or COUNTERCLOCK-WISE button at the same time enables the boom to rotate in the direction selected. The boom will rotate through 700 degrees until the buttons are released or the stop is reached.

### **9-14. Boom Raise/Down Buttons**

Pressing and holding a desired SPEED button and the UPPER, LOWER or JIB BOOM RAISE button at the same time will raise the boom. Pressing a desired SPEED button and the UPPER, LOWER or JIB BOOM DOWN button at the same time will lower the boom. Boom motion continues until the buttons are released or until each boom reaches a hard stop or a safe travel limit.

### **15-16. Boom Extend/Retract Buttons**

Pressing and holding a desired SPEED button and the BOOM EXTEND button at the same time extends the telescopic boom. Pressing and holding a desired SPEED button and the BOOM RETRACT button at the same time retracts the boom. Boom motion continues until the buttons are released or until the boom reaches a hard stop or a safe travel limit.

### **17-18. Platform Tilt Buttons**

Press and hold any SPEED button and the desired PLATFORM TILT button at the same time to level the work platform (levels the platform only, not the boom lift).

### **Outlet**

The outlet is provided for running electrical power tools from the work platform. A connecting power cord must be plugged into a suitable power source. The power plug is located on the trailer frame, in front of the accessory equipment stowage plate. The outlet is rated for a 15-ampere load. Do not overload the accessory power circuit.

## NORMAL OPERATING PROCEDURE

Perform the following procedures to operate the Bil-Jax Telescoping Boom Lift.

- ❑ Read and obey all safety precautions and operating instructions, as well as all applicable government regulations.
- ❑ Conduct a Pre-Operation Inspection by performing all recommended Daily Service Checks. Refer to Section 4.
- ❑ Position the boom lift at the work area. Make sure the boom lift is on a firm and level surface and there are no potential hazards such as overhead obstructions or electrically charged conductors. Do not operate the boom lift if such hazards exist.
- ❑ Apply the boom lift parking brake or chock the wheels.
- ❑ Lower the tongue jack and unhitch the boom lift from the tow vehicle.

### **! WARNING**

**Failing to unhitch the boom lift before operation may lead to damage to equipment or tow vehicle and makes the boom lift unstable, which can cause personnel injury or death.**

- ❑ Turn the key switch on the ground control station to operate ground controls. If power does not come on, make sure both emergency STOP buttons (ground and platform) are pulled out and the main power disconnect is plugged in.
- ❑ The control microprocessor will perform self-diagnostics to test the operating system. After several seconds, the DISPLAY PANEL window will read:

#### **BIL – JAX A STEP ABOVE**

- ❑ Verify that the control status indicator LED is lit. If the control status indicator LED is not lit or is flashing, the outrigger buttons will not work. A flashing control status LED indicates that one or more of the booms is raised and needs to be stowed. Refer to Figure 3-1 and Figure 3-3.
- ❑ Extend the outriggers manually or using the AUTO LEVEL button. When the boom is leveled properly, a buzzer will sound and two LEDs at each OUTRIGGER button and the LED at the AUTO LEVEL button will be lit.

**Auto Level:** Press and hold the EXTEND and AUTO LEVEL buttons at the same time.

**Manual Level:** Extend the two outriggers closest to the trailer coupler first. Lower each pair of outriggers by pressing the EXTEND button

and the two appropriate OUTRIGGER buttons at the same time.

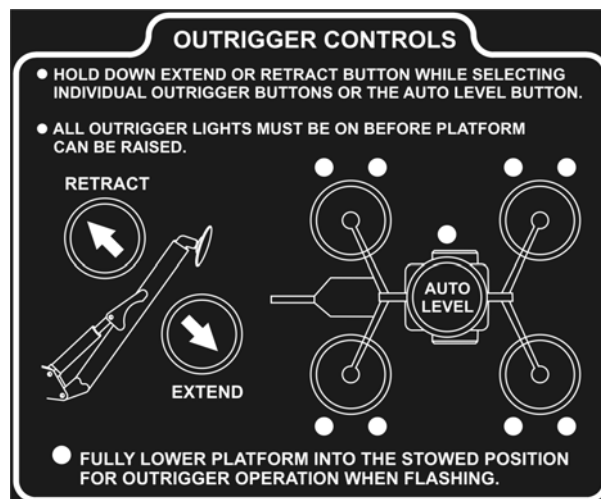
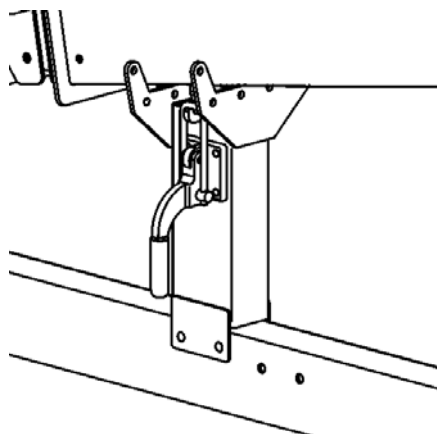

**Figure 3-3. Outrigger Controls**

**NOTE:** The safety interlock system prevents all boom operations if the boom is not level or if one or more outriggers are not supporting the vehicle load.

**NOTE:** The Range of Motion Diagrams at the ground and platform control stations display the range of platform motion (safe operating zone) facing away from the trailer tongue. Verify that the operating zone is clear of obstructions through 700° of turntable rotation.

- ❑ Verify that the auto level indicator LED is lit. If the auto level indicator is not lit, the boom may not be level.
- ❑ Pull the latch release on the boom travel latches, raise the latch handle and swing the latch U-bolt down. Refer to figure 3-4.



**Figure 3-4. Boom Travel Latch**

- ❑ Verify that the platform is properly attached to the mounting bracket on the boom end. The Retaining Pin should be fully inserted through the platform and the mounting bracket on the boom end.



**WARNING**  
**Failure to verify proper attachment of the platform to the boom end could cause the platform to separate from the boom, resulting in serious injury or death to the operator.**

- ❑ Use the ground control panel to operate the boom lift functions. Raise, lower, extend and rotate the boom by pressing and holding the desired SPEED and function buttons at the same time. Become familiar with the location and function of all controls. Learn to smoothly start and stop all boom motions.
- ❑ Fully lower the boom onto the boom rest to position the platform for boarding. Turn the key switch to the platform control position.
- ❑ Raise the safety bar and enter the work platform. Put on the safety harness and attach the lanyard to the Fall Protection Attachment Point on the side of the platform support beam.
- ❑ Use the platform control panel to operate the boom lift functions. Raise, lower, extend and rotate the boom by pressing the desired SPEED and function buttons at the same time. Become familiar with the location and function of all controls. Learn to smoothly start and stop all boom motions.
- ❑ Should the platform become tilted out of the normal vertical axis, press and hold the desired SPEED button and one of the PLATFORM TILT buttons at the same time to adjust.
- ❑ Monitor the Battery Condition Indicator during operation and charge the batteries as necessary.
- ❑ Always fully retract, rotate and lower the boom to the stowed position before exiting the platform.
- ❑ When all boom lift operations are complete, fully retract the telescoping boom extension. Center boom over the boom rest and fully lower boom until seated in the stowed position for transport. Safety switches prevent outrigger retraction until boom is completely lowered and stowed for transport.
- ❑ Unfasten the safety harness and exit platform.
- ❑ Turn the key switch to the ground controls position.
- ❑ Press and hold the outrigger RETRACT button and the AUTO LEVEL button until all outriggers are fully retracted to their upright positions. Inspect the area beneath lift and trailer for obstructions before retracting outriggers.
- ❑ Turn the key switch to the OFF position and remove key.

## MANUAL BOOM OPERATION

Manual retraction, rotation and lowering functions allow the Telescoping Boom Lift to be moved and lowered during hydraulic power interruption or failure. In each instance, refer to Figure 3-5.

The following procedures for manual retraction, rotation and lowering require a person on the ground to operate the manual controls and hand pump.

The hydraulic hand pump is located in the pump compartment. In case of a power failure, the hand pump and selected hydraulic valve settings can be used to manually retract the Telescoping boom or rotate the boom turntable.

To begin manual retraction or rotation, turn Proportional Valve counterclockwise until it stops, and insert pump handle into the pump handle fitting.

### **Manual Retraction**

Pushing and holding the Retract button while simultaneously actuating Hand Pump will retract the extension boom section.

### **Manual Rotation**

**To rotate the turntable clockwise:** Push and hold the Rotation button and simultaneously actuate Hand Pump.

**To rotate the turntable counterclockwise:** Pull the Rotation button out and simultaneously actuate Hand Pump.

**NOTE: Return proportional valve to its original position before lowering the lift or resuming normal operation.**

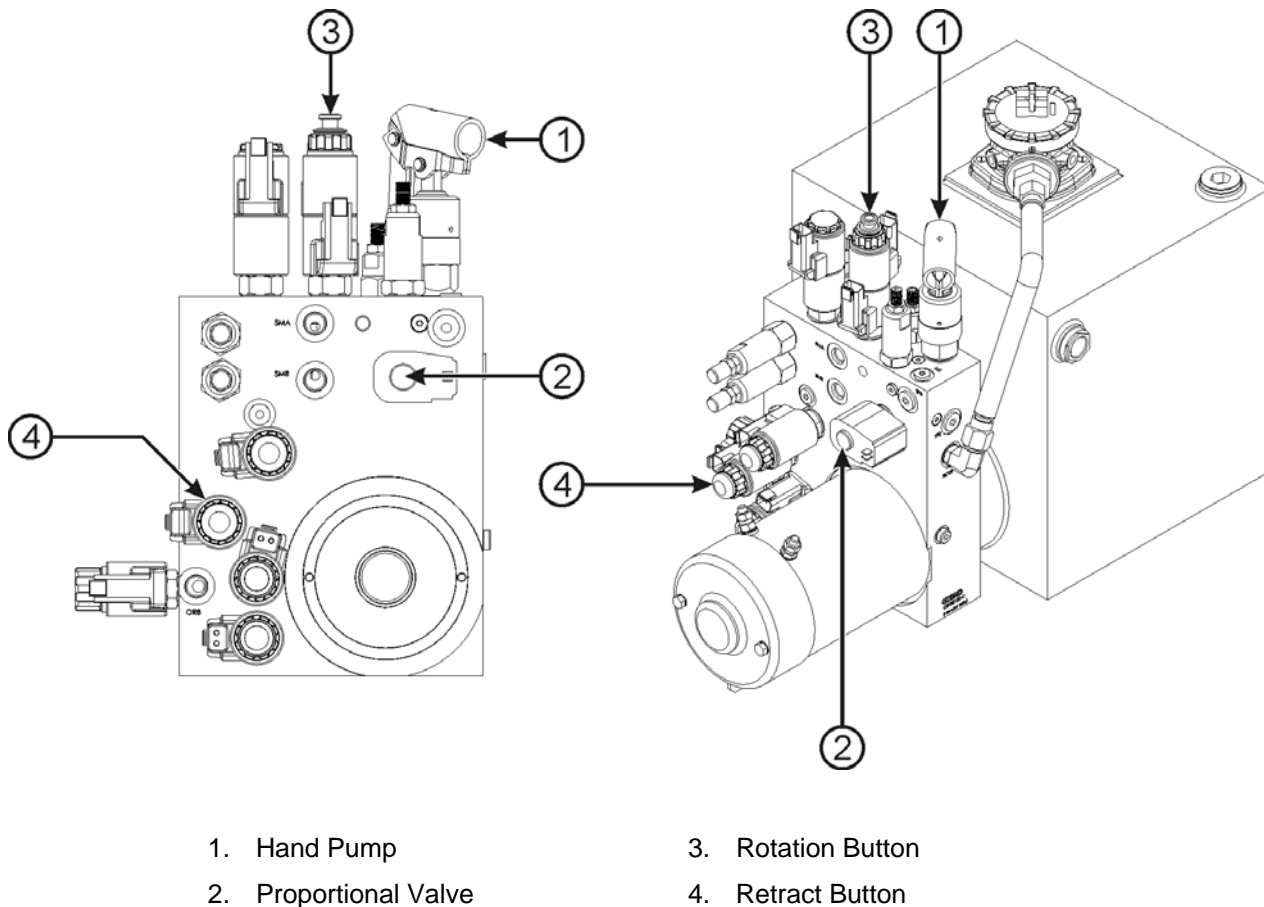

- |                       |                    |
|-----------------------|--------------------|
| 1. Hand Pump          | 3. Rotation Button |
| 2. Proportional Valve | 4. Retract Button  |

**Figure 3-5. Hand Pump and Controls for Manual Lift Operation**

### **Manual Lowering**

Each Manual Lowering Valve is equipped with a plunger, found at the base of each lift cylinder (Figure 3-6). Use the plunger to lower the platform in case of a complete electrical power failure, a load shift, or other emergency. To lower the work platform, pull the valve plunger forward. Continue pulling the plunger to completely lower the boom.

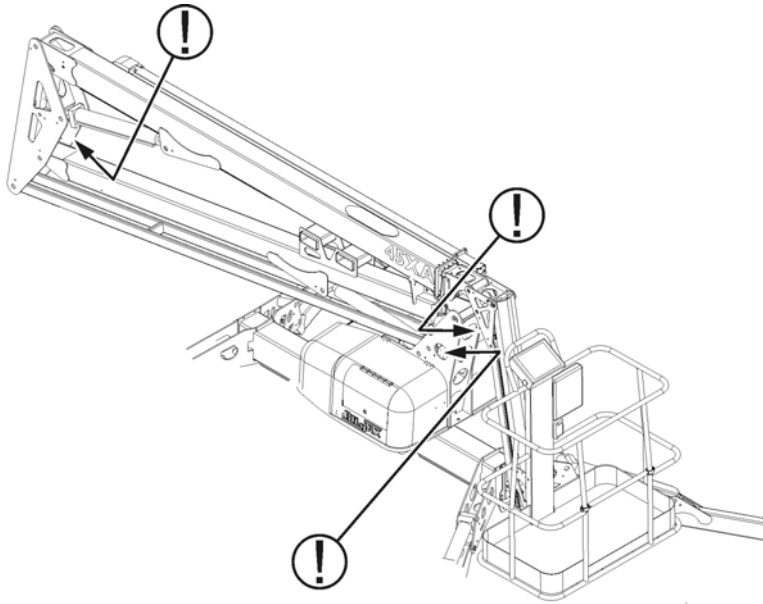

**Figure 3-6. Manual Lowering Valve**

## BATTERY RECHARGE

Recharge boom lift batteries after each 8-hour work shift or as needed. When boom lift is not in use, batteries should be recharged at least once per week. Under normal circumstances, battery recharge should take approximately 10-12 hours. However, a full recharge may take up to 24 hours, if the battery charge is extremely low.

**! WARNING**  
**Recharge batteries in a well-ventilated area only. Do no charge batteries near fire, spark or other potential ignition sources. Batteries may emit highly explosive hydrogen gas while charging. Failure to properly ventilate the charge gases may result in serious injury or death. Always charge boom lift batteries away from flammable materials.**

To recharge the boom lift batteries:

- ❑ Move the boom lift to a well-ventilated area with direct access to 120v (CE: 220v) electrical outlet. Keep the boom lift and batteries away from open flame or other potential ignition sources.
- ❑ Attach a 12 AWG multi-strand, grounded extension cord with a maximum length of 15 meters to the receptacle located on the cargo plate in front of the turntable.

**NOTE: Using an underrated or long power cord will reduce the output of the battery charger and may extend charge time.**

- ❑ Plug the extension cord into outlet. Verify that the green CHARGING indicator LED is lit on the battery charger faceplate (Figure 3-7).

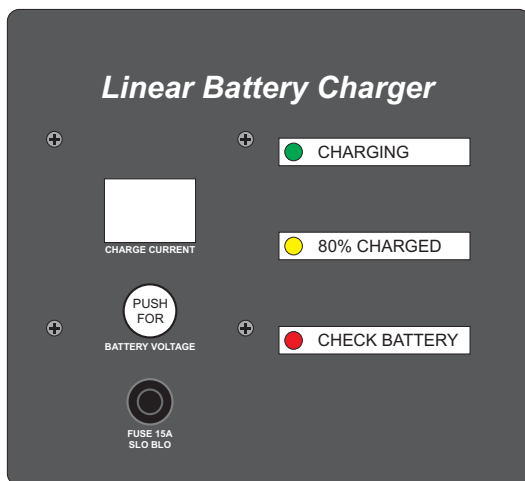

Figure 3-7. Battery Charger Faceplate

- ❑ The CHARGING indicator LED remains lit continuously during the first stage of the charge cycle. The bulk mode CHARGE CURRENT will be displayed on the battery charger faceplate.
- ❑ Press and hold the BATTERY VOLTAGE button to display the detected battery voltage.
- ❑ If a battery fault is detected, the appropriate fault code will appear on the CHARGE CURRENT display. The red CHECK BATTERY indicator LED will become lit. See Table 3-1 for battery charger fault codes.

**! WARNING**  
**Do not disconnect any output leads or connectors between the batteries and the charger when the charger is on. To stop a charge in progress, always unplug the extension cord from the AC power source.**

- ❑ When the battery charge reaches 80% of capacity, the yellow 80% CHARGED indicator LED will become lit and the green CHARGING indicator LED will begin to flash.
- ❑ When the batteries have reached a full charge, the green and yellow indicator LEDs will turn themselves off. CC (Charge Complete) will appear on the CHARGE CURRENT display. After two hours, this display will fade and the CHARGE CURRENT will read 00.
- ❑ Unplug the extension cord from the outlet and the charger receptacle on the boom lift. Store the extension cord for next use.

**! CAUTION**  
**Always unplug the battery charger power cord before moving the boom lift. Failure to disconnect power cord will cause damage to the equipment.**

Table 3-1. Charger Fault Codes

Code	Description	Limits	Cause
F1	Over Voltage	>112% charge voltage	Loose battery or charger connection
F2	Over Current	>60 amperes	Battery Fault
F3	Bulk Mode Timeout	14 hrs Max.	Battery Fault
F4	ARD Mode Timeout	6 hrs Max.	Battery Fault
F5	FCT Mode Timeout	2.5 hrs Max.	Battery Fault
F6	Self-Test Error		Charger Fault

## BOOM LIFT TRANSPORT

The boom lift trailer includes a single axle, two-inch ball hitch, hydraulic surge brakes, mechanical parking brake, safety chains, brake lights and side marker lights. Proper boom transport requires the proper attachment and inspection of these components before towing. Refer to Figure 3-8.

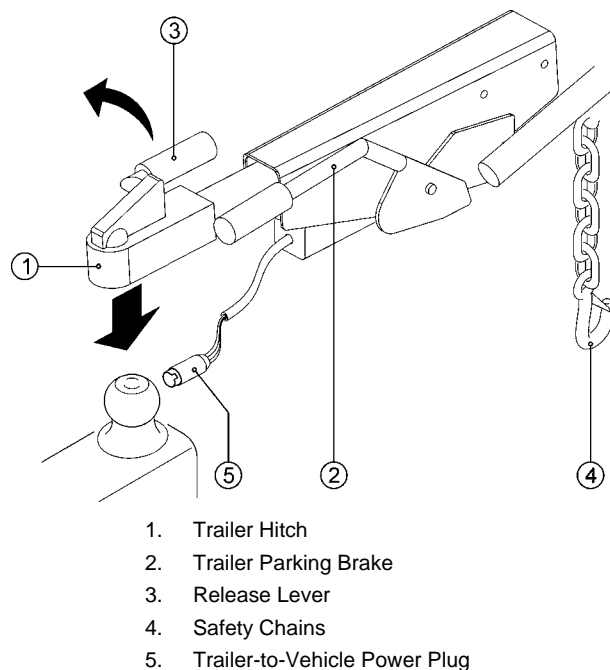

**Figure 3-8. Trailer Hitching**

Use the following procedure to hitch and tow the boom lift.

- ❑ Back the tow vehicle to the trailer. Verify that the ball and hitch are aligned and that the trailer hitch has proper clearance above the ball. Use the tongue jack as needed.



### CAUTION

**Obtain, read and obey all recommendations set forth by the tow vehicle manufacturer before attempting to transport equipment. Verify that equipment weight does not exceed the vehicle's towing capacity. Exceeding the tow vehicle's rated capacity may result in damage to tow vehicle or boom lift.**

- ❑ Lift release lever and lower the hitch onto the ball using the tongue jack. Push down the release lever to secure the ball.
- ❑ Use the tongue jack to verify secure coupling. If using the jack will raise the bumper of the tow vehicle 2-3 inches, the ball hitch coupling is secure.
- ❑ Release the trailer parking brake.

- ❑ On the tongue jack, pull the pivot locking pin and swivel jack 90 degrees to the travel position. Reengage pivot locking pin.
- ❑ Attach the safety chains to the tow vehicle. Verify that the chains cross under the trailer tongue. If necessary, cross the chains first over then under the tow bar to prevent dragging.



### CAUTION

**Failure to attach safety chains properly before towing will allow trailer tongue to drop in case of ball hitch failure, resulting in damage to trailer and equipment.**

- ❑ If equipped, connect the breakaway cable to the tow vehicle. Leave adequate slack to prevent brakes from dragging.
- ❑ Connect the trailer lights to the tow vehicle power plug.

Verify the following before towing the lift. Make adjustments as necessary.

- ❑ The trailer jack and outriggers are in their travel positions.
- ❑ Boom travel latches are engaged, securing the booms in their fully stowed positions.
- ❑ All on-board equipment is secured.
- ❑ The key switch is in the OFF position. Remove the key.
- ❑ The parking brake is disengaged.
- ❑ The trailer tires are adequately and evenly inflated.

Periodically check the wheel nut torque according to manufacturer's recommendations. Frequent torque checks are required when a wheel is recently installed.

Prior to towing, while the trailer wheels are elevated for boom lift operation, inspect for loose wheels and for wheel lug wear. If a loose wheel mounting is suspected, remove and inspect wheel lugs for damage. NEVER tow a boom lift with worn or damaged wheel components.

## BOOM LIFT TRANSPORT

### LIFTING INSTRUCTIONS

Refer to Figure 3-9.

- ❑ Completely lower and retract boom.
- ❑ Secure boom travel latches.
- ❑ Remove all loose materials from machine.
- ❑ Retract all outriggers to fully stowed position.
- ❑ Attach rigging only to the designated forklift pockets (A).
- ❑ Adjust rigging to keep the machine level and to minimize the risk of damage to machine.
- ❑ When using a forklift, use only the designated forklift pockets. Follow all forklift operating instructions as indicated by the forklift manufacturer.
- ❑ Only trained and authorized personnel should attempt to lift the boom using a crane or forklift.

### TRANSPORT INSTRUCTIONS

Refer to Figure 3-9.

- ❑ Verify that truck or trailer is parked on a firm and level surface.
- ❑ Completely lower and retract boom.
- ❑ Secure boom travel latches.
- ❑ Retract all outriggers to fully stowed position.
- ❑ Load boom onto truck or trailer.
- ❑ Chock the wheels (B) and apply parking brake.
- ❑ Place a wooden block under the tongue, near the trailer hitch (C).
- ❑ Lower jack until trailer tongue rests on the wooden block. Swing up and lock the jack (D) so that the weight of the tongue now rests on the wooden block.
- ❑ Secure the boom lift to the trailer bed using straps or chains. Use only the two attachment points beneath the machine, adjacent to the outriggers (E).
- ❑ Adjust as necessary to prevent damage to rigging or machine.

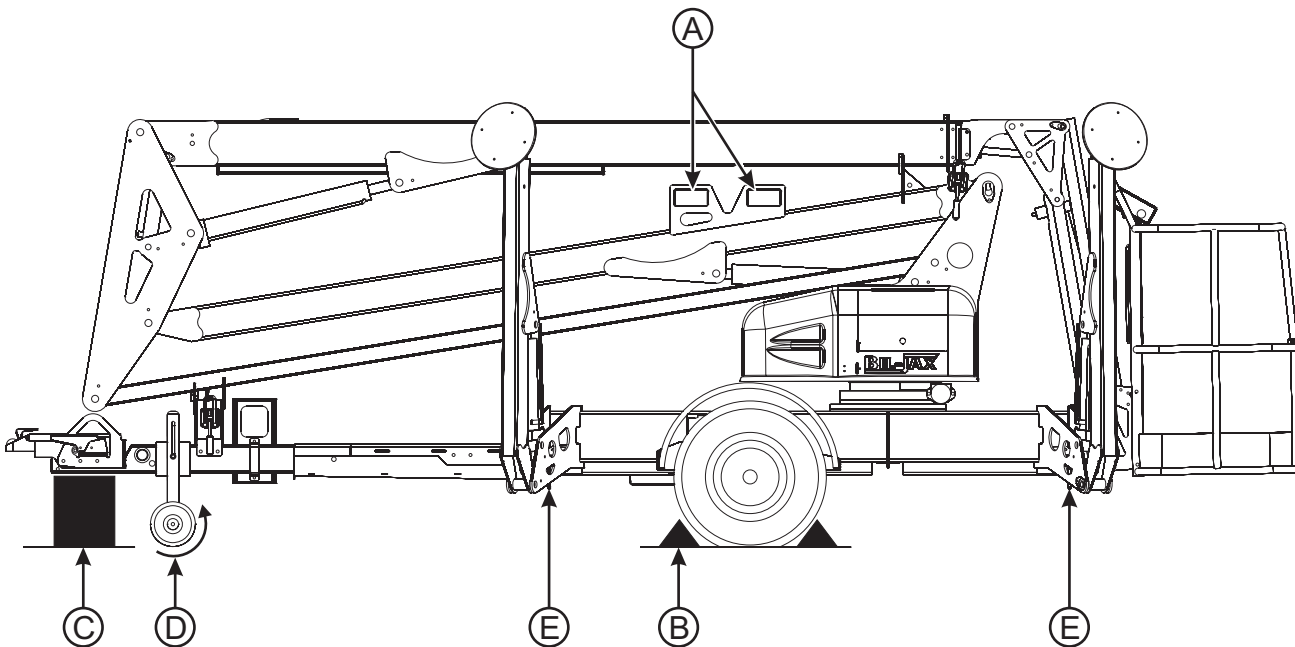

Figure 3-19. Lift and Transport Instruction

# 4 OPERATOR SERVICE

---

Performing the appropriate maintenance procedures will extend the life of the boom lift and will help ensure the safety of personnel operating the equipment.

Repair, replacement or adjustment of any hydraulic or electrical control device should be performed only by fully trained and authorized personnel. These include, but are not limited to, hydraulic load valves, hydraulic flow control valves, solenoid valves and limit switches. These are safety related controls. Improper adjustment or tampering with these devices may impair boom lift function and result in safety or damage hazards.

Persons performing maintenance or repairs on the machine should be trained in accordance with the manufacturer's recommendations. Contact your regional Bil-Jax representative if additional information is needed.

Critical or suspect areas identified during any scheduled inspection of the machine shall be examined by qualified personnel in accordance with applicable government regulations.

Never operate the machine if a defect or malfunction is identified or suspected. All defects and malfunctions must be repaired, and all maintenance performed, before returning a machine to service.

This manual contains a list of recommended maintenance procedures to be performed daily, weekly and monthly. Refer to the appropriate Summit Series Parts and Service Manual for a list of annual service checks.

It is the practice of Bil-Jax, Inc. to issue Service and/or Safety Bulletins, which may include updates to the information contained in this manual. In such instances, procedures contained in Bil-Jax Service Bulletins or Safety Bulletins supersede the information contained in manuals.

Always follow maintenance schedule, regardless of use.

## DAILY SERVICE CHECKS

The following Maintenance Procedures should be performed daily or before each operation.

### Verify that all decals are correctly applied and in plain view.

- ❑ Refer to Section 5 for decal locations.

### Verify that all controls and indicators at ground and platform control stations operate properly.

- ❑ Lower outriggers to level the boom lift.
- ❑ Raise and extend all booms.
- ❑ Press emergency STOP button.
- ❑ Verify that booms remain elevated and do not drift.
- ❑ Pull out STOP button and lower the booms.
- ❑ If either control station is unresponsive, refer to Table 4-1 for troubleshooting procedures.
- ❑ If display panel displays an error code, refer to Table 4-2 for error code definitions.

### Verify operation of running and brake lights.

#### Verify correct tire inflation.

- ❑ In cold climates, inflate tires to 55 psi.

#### Inspect tires for damage or loose or missing lug nuts.

- ❑ Repair or replace as necessary.

#### Inspect structural components and platform for obvious damage or debris.

- ❑ Repair or replace as necessary.

#### Inspect machine for missing, loose or damaged fasteners, including pins and bolts.

### Verify that boom down limit switches operate correctly.

- ❑ Down limit switches are actuated when the boom is in a fully lowered, stowed position. Limit switches must be operational to raise or lower outriggers.
- ❑ If outrigger controls are unresponsive when boom is fully lowered and stowed, inspect down limit switches for loose mounting or visible damage.
- ❑ Repair or replace as needed.

### Verify that outrigger safety interlocks operate correctly.

- ❑ Begin with the outriggers fully extended and the boom lift level. Raise one outrigger until the footpad is not in contact with the ground.
- ❑ Verify that boom functions are unresponsive when one outrigger is raised.
- ❑ Repeat this procedure for each outrigger.
- ❑ Raise all outriggers until the footpads are not in contact with the ground. Verify that all outrigger status LEDs on the ground control panel are unlit.
- ❑ Lower one outrigger until the footpad makes contact with the ground and the outrigger begins lifting the trailer.
- ❑ If the LED is lit before the footpad makes contact with the ground or if the LED remains unlit after the weight is transferred to the outrigger, the position switch or wiring is faulty.
- ❑ Repeat this procedure for each outrigger.
- ❑ Repair or replace as needed. Refer to Figure 4-1.

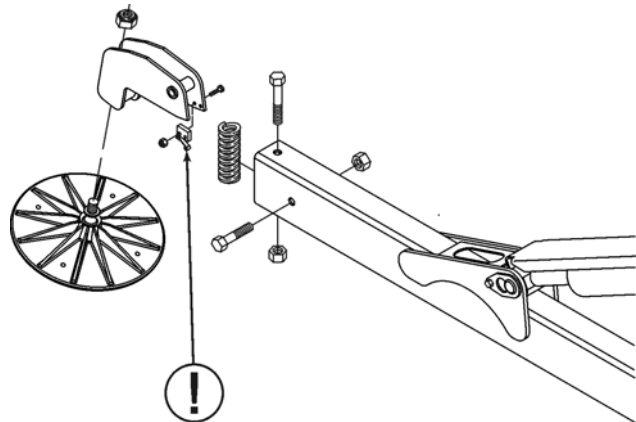

Figure 4-1. Outrigger Position Switches

**Inspect hydraulic system and fluid levels.**

- ❑ Check all hydraulic hoses and fittings for leaks and damage. Tighten or replace as necessary to prevent hydraulic oil or pressure loss.
- ❑ The hydraulic oil level should be checked with the booms down, all outriggers raised and the trailer wheels on a level surface.
- ❑ Hydraulic oil level should be visible in, but not above, the sight gauge.
- ❑ If the hydraulic oil level is not visible to at least half way up the sight gauge (Figure 4-2), add clean hydraulic fluid as necessary while all booms and outriggers are fully retracted and stowed. Pour slowly to avoid creating air pockets in the reservoir. Do not fill above sight gauge. Overfilling the hydraulic reservoir may cause damage to hydraulic lines and may result in equipment malfunction.

**CAUTION**

**Do not mix hydraulic oils. Do not add any fluid to the hydraulic system that is not expressly recommended by the manufacturer. Adding unauthorized fluids to the hydraulic system may cause damage to equipment**

- ❑ The hydraulic reservoir is originally filled with Dexron III/Mercon ATF with a viscosity rating of 175.
- ❑ Manufacturer recommends a higher viscosity hydraulic oil when operating equipment routinely in extreme climates.

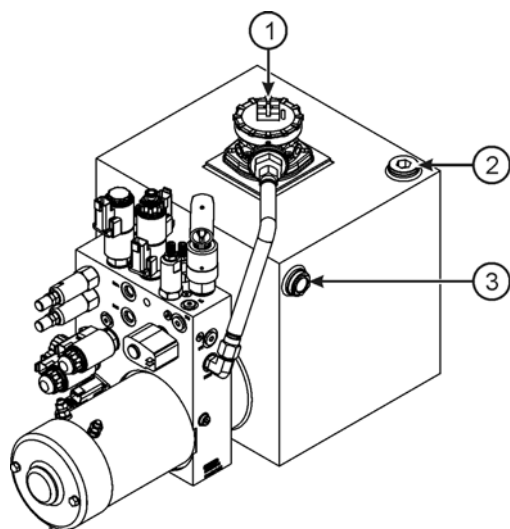

1. Filter Element
2. Fill Port
3. Sight Gauge

**Figure 4-2. Hydraulic Reservoir**

## **WEEKLY SERVICE CHECKS**

Perform the following service checks at least once each week in addition to all recommended Daily Service Checks:

### **Check Battery electrolyte level.**

- If battery charge is low, add enough water to bring the electrolyte level to the top of the plates.
- If batteries are fully charged, raise electrolyte level to full mark in each cell.

### **Inspect all electrical wiring.**

- Check for cuts, loose terminals, broken wires, chaffing and corrosion.
- Repair all damage, remove corrosion and seal exposed connections.

### **Inspect transport hitch components for damage.**

### **Inspect boom lift for missing, loose or damaged hardware.**

- Repair or replace as necessary.

### **Inspect all hydraulic system components including pump and motor and cylinders for damage, leaks, loss of pressure or speed, and unusual noise or vibration.**

- Repair or replace as necessary.

## MONTHLY SERVICE CHECKS

Perform the following service checks at least once each month:

**Clean all battery terminals.**

**Check battery for loose connections or damaged wires.**

**Verify proper operation of manual lowering valves and hand pump**

- ❑ Refer to Section 3 for manual boom operating procedures.

**Lubricate all compartment hinges and latches, slew ring and mating gear.**

- ❑ Use NLGI Grade 2 multi-purpose grease.

**Check wheel nut torque.**

- ❑ Refer to Figure 4-3 for correct wheel nut tightening sequence.
- ❑ Evenly tighten wheel nuts to 34 N\*m in the tightening sequence shown.
- ❑ Repeat sequence, tightening wheel nuts to 81 N\*m and to 136 N\*m.

**NOTE: When wheels are newly installed or replaced, verify wheel nut torque after 75 and 150 km of travel and monthly thereafter. Follow this procedure each time the wheel is removed and reinstalled.**

## ADDITIONAL SERVICE INFORMATION

Refer to the Bil-Jax Parts and Service Manual for a comprehensive list of Annual service checks.

Seals on hydraulic cylinders should be replaced every five years or as indicated by machine performance.

All service checks should be performed on a machine that has been stored without use for a period exceeding thirty days.

Check for air in the hydraulic system if the machine has been stored without use for a period exceeding thirty days, or if the machine was stored without use during a seasonal climate change. Air trapped in the hydraulic system will affect machine performance. Follow procedures for bleeding air from the hydraulic system, found in the Bil-Jax Parts and Service manual.

Owners and lessors should complete a full inspection of all components and perform a test of all functions, including brake functions, before commissioning or reselling machine. Always repair or replace all damaged or malfunctioning components before commissioning or reselling machine.

When a change in ownership occurs, it is the responsibility of the seller to provide the new owner with all manuals for the machine. It is the responsibility of the buyer to notify the manufacturer of the unit model and serial number and the name and address of the new owner within 60 days.

Use the Service Checklists found at the back of this manual to record all Service Checks as well as any maintenance, repairs or alterations performed on the machine.

Records of frequent safety checks need not be made. However, where a safety hazard is found, it shall be reported in writing to the owner of the machine, and a record of any corrective action shall be maintained for five years or as required by the authority having jurisdiction.

Refer to the Bil-Jax Parts and Service Manual for a comprehensive list of Annual service checks.

**Figure 4-3. Wheel Nut Tightening Sequence**

## TROUBLESHOOTING

Refer to Table 4-1 for basic troubleshooting operations. Additional information can be found in the Bil-Jax Parts and Service Manual. Contact the Bil-Jax Service Department with any questions or before attempting any advanced troubleshooting operations.

**Table 4-1. Troubleshooting Steps**

<b>PROBLEM</b>	<b>CAUSE</b>	<b>SOLUTION</b>
No lights on panel when key switch is turned to the on position.	<ul style="list-style-type: none"> <li>a. Emergency STOP engaged.</li> <li>b. Battery charge is low.</li> <li>c. Battery ground or in-series cable is loose.</li> <li>d. Battery main disconnect unplugged.</li> <li>e. Blown Fuse.</li> </ul>	<ul style="list-style-type: none"> <li>a. Disengage Emergency STOP buttons.</li> <li>b. Recharge as needed.</li> <li>c. Inspect and repair battery connections.</li> <li>d. Plug in main disconnect.</li> <li>e. Check and replace fuse.</li> </ul>
Hydraulic function does not work and display window shows an error message	<ul style="list-style-type: none"> <li>a. Fault detected by safety interlock microprocessor.</li> <li>b. Boom Lift electric or electronic failure</li> </ul>	<ul style="list-style-type: none"> <li>a. Refer to Table 4-2 for error code definition and correction.</li> <li>b. Refer to Table 4-2 for error code definition and correction.</li> </ul>
Outrigger indicator LED lights do not function.	<ul style="list-style-type: none"> <li>a. Key switch turned to the OFF or platform controls position.</li> <li>b. Emergency STOP engaged.</li> <li>c. Outriggers not deployed.</li> </ul>	<ul style="list-style-type: none"> <li>a. Turn key switch to ground controls position.</li> <li>b. Disengage emergency STOP buttons.</li> <li>c. Deploy all outriggers.</li> </ul>
<p>One or more boom controls do not function</p> <p><b>OR</b></p> <p>One or more boom controls function improperly</p> <p><b>OR</b></p> <p>One or more boom controls function intermittently.</p>	<ul style="list-style-type: none"> <li>a. Key switch is turned to the OFF or incorrect control position.</li> <li>b. Battery charge is low.</li> <li>c. Emergency STOP engaged.</li> <li>d. Battery ground or in-series cable loose.</li> <li>e. All outriggers not properly deployed.</li> <li>f. Hydraulic pump inoperative.</li> <li>g. Loose wiring connector.</li> <li>h. Valve solenoid not operating properly.</li> <li>i. Fault detected by system interlock.</li> <li>j. Broken or loose wire.</li> </ul>	<ul style="list-style-type: none"> <li>a. Turn key switch to ground or platform controls position.</li> <li>b. Recharge battery.</li> <li>c. Disengage Emergency STOP buttons.</li> <li>d. Inspect and repair battery connections.</li> <li>e. Deploy all outriggers and level boom lift.</li> <li>f. Inspect pump; replace or repair as needed.</li> <li>g. Check wiring terminals in control box and at valve manifold; replace or repair as needed.</li> <li>h. Clean valve solenoid and recheck function(s); replace or repair as needed.</li> <li>i. Check display for system status. Refer to Table 4-2 for error code definitions and correction.</li> <li>j. Inspect wiring in control box and at valve manifold and valve coil; repair or replace as needed.</li> </ul>

## ERROR CODE DEFINITIONS

The DISPLAY PANEL located on the ground control panel indicates the present operating status of the boom lift. If an error condition is detected by the control processor during start-up or operation, the appropriate error code will be displayed on this panel.

Refer to Table 4-2 for a comprehensive list of Error Code Definitions and solutions.

**Table 4-2. Error Code Definitions**

ERROR MESSAGE	DEFINITION OF ERROR	COMMENTS
001 MACHINE IS IN DOWN ONLY MODE	Machine was either never leveled, outriggers not lowered, or machine went out of level with use.	Retract boom to travel position and extend outriggers using AUTO LEVEL button.
002 LOSS OF PLATFORM COMMUNICATION	Ground control lost communication with platform control.	Check for unplugged or damaged platform control cable.
005 PLATFORM CONTROL HAS STUCK KEY	Platform control detected a stuck or pressed key on power up.	Turn key switch off and on again without pressing any buttons.
008 GROUND CONTROL HAS STUCK KEY	Ground control detected a stuck or pressed key on power up.	Turn key switch off and on again without pressing any buttons.
009 BOOM UP WITHOUT OUTRIGGERS ON GROUND	Ground control detected the boom is up and all outriggers are not on the ground	Retract boom to travel position and extend outriggers using AUTO LEVEL button.
010 LEVEL SENSOR HAS ERRATIC OUTPUT	The ground control detected an erratic output from the level sensor.	Retract and extend outriggers using AUTO LEVEL button.
015 MACHINE IS NOT LEVEL	Machine has gone out of level with use.	Retract and extend outriggers using AUTO LEVEL.
016 LIFT BOOM	A boom rotate, extend, or retract function requested with boom down.	Raise boom from travel position.
017 STOW BOOM	An outrigger function requested with boom up.	Retract and lower boom to travel position.
021 OPEN CIRCUIT PRIMARY UP	A load of less than 70mA detected in primary up circuit on power-up.	Check for faulty boom up solenoid coil and wiring.
022 SHORTED CIRCUIT PRIMARY UP	Excessive load detected in primary up circuit on power-up.	Check for faulty boom up solenoid coil and wiring.
023 OPEN CIRCUIT PRIMARY DOWN	A load of less than 70mA was detected when primary down circuit was energized	Check for faulty boom down solenoid coil and wiring.
024 SHORTED CIRCUIT PRIMARY DOWN	Excessive load detected when primary down circuit was energized.	Check for faulty boom down solenoid coil and wiring.
025 OPEN CIRCUIT SECONDARY UP	A load of less than 70mA detected in secondary up circuit on power-up.	Check for faulty boom up solenoid coil and wiring.
026 SHORTED CIRCUIT SECONDARY UP	Excessive load detected in secondary up circuit on power-up.	Check for faulty boom up solenoid coil and wiring.
027 OPEN CIRCUIT SECONDARY DOWN	A load of less than 70mA detected when secondary down circuit was energized	Check for faulty boom down solenoid coil and wiring.
028 SHORTED CIRCUIT SECONDARY DOWN	Excessive load detected when secondary down circuit was energized.	Check for faulty boom down solenoid coil and wiring.
029 OPEN CIRCUIT JIB UP	A load of less than 70mA detected in jib up circuit on power-up.	Check for faulty jib up solenoid coil and wiring.
030 SHORTED CIRCUIT JIB UP	Excessive load detected in jib up circuit on power-up.	Check for faulty jib up solenoid coil and wiring.

ERROR MESSAGE	DEFINITION OF ERROR	COMMENTS
031 OPEN CIRCUIT JIB DOWN	A load of less than 70mA detected when jib down circuit was energized	Check for faulty jib down solenoid coil and wiring.
032 SHORTED CIRCUIT JIB DOWN	Excessive load detected when jib down circuit was energized.	Check for faulty jib down solenoid coil and wiring.
033 OPEN CIRCUIT EXTEND	A load of less than 70mA detected in extend circuit on power-up.	Check for faulty boom extend solenoid coil/wiring.
034 SHORTED CIRCUIT EXTEND	Excessive load detected in extend circuit on power-up.	Check for faulty boom extend solenoid coil/wiring.
035 OPEN CIRCUIT RETRACT	A load of less than 70mA detected in retract circuit on power-up.	Check for faulty boom retract solenoid coil/wiring.
036 SHORTED CIRCUIT RETRACT	Excessive load detected in retract circuit on power-up.	Check for faulty boom retract solenoid coil/wiring.
037 OPEN CIRCUIT PLATFORM LEVEL UP	A load of less than 70mA detected in platform level up circuit on power-up.	Check for faulty level up solenoid coil/wiring.
038 SHORTED CIRCUIT PLATFORM LEVEL UP	Excessive load detected in platform level up circuit on power-up.	Check for faulty level up solenoid coil/wiring.
039 OPEN CIRCUIT PLATFORM LEVEL DOWN	A load of less than 70mA detected in platform level down circuit on power-up.	Check for faulty level down solenoid coil/wiring.
040 SHORTED CIRCUIT PLATFORM LEVEL DOWN	Excessive load detected in platform level down circuit on power-up.	Check for faulty level down solenoid coil/wiring.
041 OPEN CIRCUIT PLATFORM CW	A load of less than 70mA detected in platform CW circuit on power-up.	Check for faulty boom rotate solenoid coil/wiring.
042 SHORTED CIRCUIT PLATFORM CW	Excessive load detected in platform CW circuit on power-up.	Check for faulty boom rotate solenoid coil/wiring.
043 OPEN CIRCUIT PLATFORM CCW	A load of less than 70mA detected in platform CCW circuit on power-up.	Check for faulty boom rotate solenoid coil/wiring.
044 SHORTED CIRCUIT PLATFORM CCW	Excessive load detected in platform CCW circuit on power-up.	Check for faulty boom rotate solenoid coil/wiring.
045 OPEN CIRCUIT TURNTABLE CW	A load of less than 70mA detected in rotate CW circuit on power-up.	Check for faulty rotate CW solenoid coil/wiring.
046 SHORTED CIRCUIT TURNTABLE CW	Excessive load detected in rotate CW circuit on power-up.	Check for faulty rotate CW solenoid coil/wiring.
047 OPEN CIRCUIT TURNTABLE CCW	A load of less than 70mA detected in rotate CCW circuit on power-up.	Check for faulty rotate CCW solenoid coil/wiring.
048 SHORTED CIRCUIT TURNTABLE CCW	Excessive load detected in rotate CCW circuit on power-up.	Check for faulty rotate CCW solenoid coil/wiring.
049 OPEN CIRCUIT OUTRIGGER RETRACT	A load of less than 70mA detected in outrigger retract circuit on power-up.	Check for faulty outrigger retract solenoid coil/wiring.
050 SHORTED CIRCUIT OUTRIGGER RETRACT	Excessive load was detected when Outrigger Retract circuit was energized.	Check for faulty outrigger retract solenoid coil/wiring.
051 OPEN CIRCUIT OUTRIGGER EXTEND	A load of less than 70mA detected in outrigger retract circuit on power-up.	Check for faulty outrigger extend solenoid coil/wiring.
052 SHORTED CIRCUIT OUTRIGGER EXTEND	Excessive load was detected in outrigger extend circuit on power-up.	Check for faulty outrigger extend solenoid coil/wiring.
053 OPEN CIRCUIT LF OUTRIGGER	A load of less than 70mA detected in left front outrigger circuit on power-up.	Check for faulty solenoid coil/wiring at outrigger.
054 SHORTED CIRCUIT LF OUTRIGGER	Excessive load was detected in left front outrigger circuit on power-up.	Check for faulty solenoid coil/wiring at outrigger.
055 OPEN CIRCUIT RF OUTRIGGER	A load of less than 70mA detected in right front outrigger circuit on power-up.	Check for faulty solenoid coil/wiring at outrigger.

ERROR MESSAGE	DEFINITION OF ERROR	COMMENTS
056 SHORTED CIRCUIT RF OUTRIGGER	Excessive load detected in right front outrigger circuit on power-up.	Check for faulty solenoid coil/wiring at outrigger.
057 OPEN CIRCUIT LR OUTRIGGER	A load of less than 70mA detected in left rear outrigger circuit on power-up.	Check for faulty solenoid coil/wiring at outrigger.
058 SHORTED CIRCUIT LR OUTRIGGER	Excessive load detected in left rear outrigger circuit on power-up.	Check for faulty solenoid coil/wiring at outrigger.
059 OPEN CIRCUIT RR OUTRIGGER	A load of less than 70mA detected in right rear outrigger circuit on power-up.	Check for faulty solenoid coil/wiring at outrigger.
060 SHORTED CIRCUIT RR OUTRIGGER	Excessive load detected in right rear outrigger circuit on power-up.	Check for faulty solenoid coil/wiring at outrigger.
069 OPEN CIRCUIT PROPORTIONAL	A load of less than 70mA detected in proportional valve circuit on power-up.	Check for faulty solenoid coil/wiring at proportional valve.
070 SHORTED CIRCUIT PROPORTIONAL	Excessive load detected in proportional valve circuit on power-up.	Check for faulty solenoid coil/wiring at proportional valve.



# 5 DECAL REPLACEMENT

---

Decals contain information that is required for the safe and proper use of the aerial work platform. Decals should be considered necessary components of the machine and should be checked before each use to verify that they are correctly attached and legible.

Use the following guides to find the correct location of all decals.

Table 5-1. Decal Descriptions

Decal No.	Decal Description	Qty
0202-0523	Made in USA	1
B06-00-0034	DANGER: Electric Shock	1
B06-00-0037	Lubricate Semi-Annually	1
B06-00-0062	NOTICE: AC Power	2
B06-00-0068	NOTICE: Hydraulic System Oil	1
B06-00-0161B	Bil-Jax Logo, 6" Black Transfer	2
B06-00-0173	NOTICE: Fall Protection Attachment Point	2
B06-00-0403	NOTICE: Emergency Lowering	4
B06-00-0404	WARNING: Outrigger Crush Toe	8
B06-00-0405	WARNING: Pinch Point	17
B06-00-0471	DANGER: Before Use/Main Instruction/Hazards (Platform)	1
B06-00-0473	NOTICE: Operator's Manual Missing	1
B06-00-0474	NOTICE: Max. Load	1
B06-00-0475	WARNING: Read/Understand Operator's Manual	1
B06-00-0477	WARNING: Forklift Pockets	2
B06-00-0478	NOTICE: Platform Charger/Power Plug Here	1
B06-00-0481	CAUTION: Transport Safety Latch	3
B06-00-0482	DANGER: Electrocution Hazard	2
B06-00-0484	DANGER: Battery/Charger Safety	1

Decal No.	Decal Description	Qty
B06-00-0494	NOTICE: Hazardous Materials	1
B06-00-0495	CAUTION: Compartment Access Restricted	2
B06-00-0496	CAUTION: Generator Plate Capacity 200 lbs.	1
B06-00-0503	NOTICE: Handle Applications	1
B06-00-0504	NOTICE: Emergency Hand Pump	1
B06-00-0505	DANGER: Before Use/Main Instruction/Hazards (ground)	1
B06-00-0521	DANGER: Tip Over Hazard	7
B06-00-0533	WARNING: Operating Instructions (Ground)	2
B06-00-0534	WARNING: Operating Instructions (Platform)	1
B06-00-0535	NOTICE: Range of Motion	2
B06-00-0538	3522A, 6" Black Transfer	2
B06-00-0541	CAUTION: Manual Boom Functions	1
B06-00-0542	WARNING: Max. Towing Speed	2
B06-00-0543	WARNING: Wheel Crush Toe	2
B06-00-0544	WARNING: Towing Hazards	2
B06-00-0545	Bil-Jax Website Transfer	2
B06-00-0550	WARNING: Unhitch Lift Before Use	2
B06-00-0551	CAUTION: Prior to Towing	1

#### Identification Plates

B06-00-0490	VIN Plate	1
B06-00-0499	ANSI ID Plate	1
B06-00-0524	Annual Inspection Plate	1
B06-00-0526	Key Tag	1

#### CE/CAN/AUS Machines

B06-00-0167	Black/Yellow Hazard - 2" Wide	4
B06-00-0568	WARNING: Tip Over Hazard	4

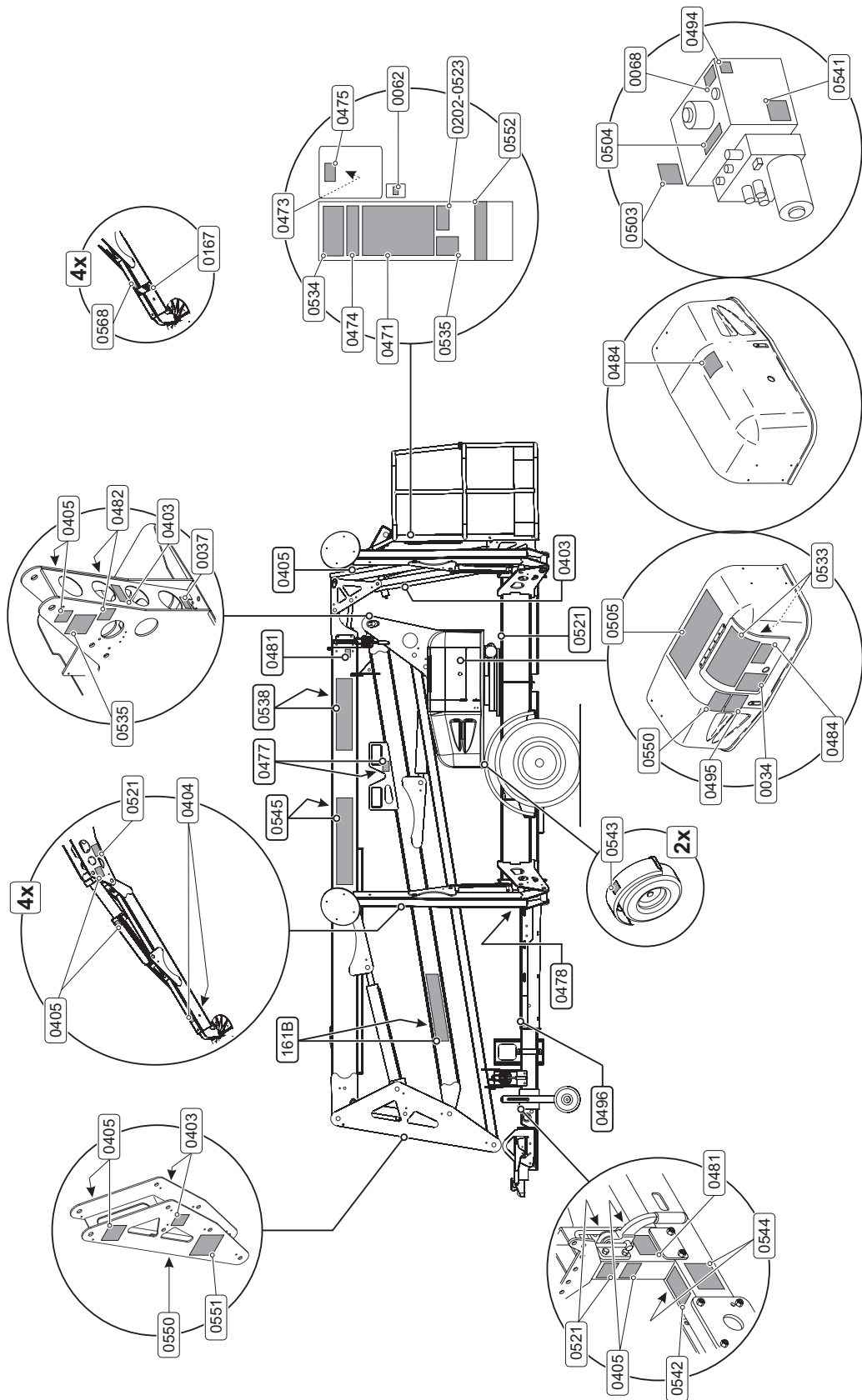

Figure 5-1. Decal Placement



# 6 ANSI REPRINT

---

The following sections are reprinted from the ANSI A92.2-2001 code in effect at the time of manufacture and govern the safe use of the Bil-Jax Model 3522A Telescoping Boom Lift. **It is the responsibility of all owners and operators of this machine to read, understand and obey the recommendations set forth by the ANSI code.**

Permission to reprint this material has been granted by the Scaffold Industry Association.

## 7. Responsibilities of Dealers and Installers

- 7.1 **General Responsibilities.** Each dealer or installer as applicable shall comply with the requirements of this section.
- 7.2 **Vehicle Specifications.** Each dealer or installer, or both, who sells an aerial device shall inform the owner or user, or both, of the manufacturer's minimum vehicle specifications.
- 7.3 **Vehicle Weight Distribution.** The installer shall be responsible for the weight distribution of the completed mobile unit in accordance with the requirements of the aerial device and the applicable regulations. Allowance shall be made for the weight of readily removable tools and material specified by the user.
- 7.4 **Manuals.** Upon delivery of the equipment to the owner or user, the dealer or installer shall provide the manuals as required by Paragraph 6.4 of this standard and manuals for auxiliary equipment added by the installer.
- 7.5 **Installations.** The installer shall comply with Sections 5 and 6 of this standard relating to proper installation and shall follow the instructions of the manufacturer. In the event the original manufacturer no longer exists, an equivalent entity may provide these instructions. The installer of an aerial device shall, before the mobile unit is placed in operation, perform stability tests in accordance with the requirements of 4.5.1 and 4.5.2, the operational and visual tests in accordance with the requirements of 6.6.1 and 6.6.2 a, and the appropriate electrical tests required in 5.4.3 of this standard. The installer shall, when installing an aerial device on a chassis which is a highway vehicle, comply with all requirements of the Federal Motor Vehicle Safety Standards in effect at the time of installation. Certification as a manufacturer (alteration, intermediate or final) of a motor vehicle under the Federal Motor Vehicle Safety Standards is required. The travel height of a mobile unit shall be posted in a location that is readily visible to the vehicle operator. For insulated aerial devices, the installer shall assure conformance to the Qualification test requirements of 5.3.2 by either obtaining certification of the test and performing a periodic test after insulation, or by performing the Qualification test.
- 7.5.1 **Quality Assurance.** The installer shall have a documented quality assurance program which will ensure compliance with this standard.
- 7.6 **Welding.** All welds made by the installer, whose failure could result in motion of the platform(s) shall meet the Structural Welding Code AWS D1.1-98 and AWS D1.2-98. The installer shall establish applicable welding quality assurance procedures for all weldments.
- 7.7 **Training.** The dealer or installer shall offer training or training materials that aid owners and users in the operation, inspection, testing and maintenance of the aerial

device. The training shall be offered initially and subsequently on request.

- 7.7.1 **Dealer or Installer as User.** Whenever a dealer or installer directs personnel to operate the aerial device (inspecting, sales demonstrations, or any form of use), the dealer or installer shall assume the responsibilities of users as specified in Section 9 of this standard. All personnel authorized to operate this aerial device shall have been trained.

## 8. Responsibilities of Owners

- 8.1 **General Responsibilities.** Each owner shall comply with the requirements of this section. The following responsibilities pertain to the owner's inspection, testing, maintenance, modification, training and transfer of ownership. These activities shall be performed by qualified person(s).
- 8.2 **Inspection and Testing Classifications.**
- 8.2.1 **Initial Inspection and Test.** Prior to initial use, all new or modified mobile units shall be inspected and tested to ensure compliance with the provisions of this standard. Verification by the manufacturer, the installer, or an equivalent entity(s) meets this requirement.
- 8.2.2 **Regular Inspection and Tests.** The inspection procedure for mobile units is divided into two classifications based upon the intervals at which inspections and tests shall be performed. Intervals shall be set by the owner in accordance with the manufacturer's recommendations. Such intervals are dependant upon component function and exposure to wear, deterioration and other agents which adversely affect component life. Two classifications are designated:
- (1) Frequent Inspection and Test: Daily to Monthly intervals.
  - (2) Periodic Inspection and Test: One to Twelve Month intervals.
- 8.2.3 **Frequent Inspection and Test.** Items determined to by the owner in accordance with the manufacturer's recommendations for each specific aerial device shall be inspected for defects. The following tests and inspections shall be performed by the operator once daily, prior to first use:
- (1) Operating controls and associated mechanisms for conditions interfering with proper operation.
  - (2) Visual and audible safety devices for malfunction.
  - (3) Hydraulic and pneumatic systems for observable deterioration or excessive leakage.
  - (4) Fiberglass and other insulating components for visible damage or contamination.
  - (5) Missing or illegible operational and instructional markings.
  - (6) Electrical systems of/or related to the aerial device for malfunction, signs of excessive deterioration, dirt and moisture accumulation.
  - (7) Visual inspection of bolts, pins and other fasteners for loose, deformed or missing fasteners and other locking

devices. Any suspected items shall be carefully examined or tested and a determination made by a qualified person as to whether they constitute a safety hazard. All unsafe items shall be replaced or repaired before use.

**8.2.4 Periodic Inspection or Test.** An inspection of the mobile unit shall be performed at the intervals defined in 8.2.2 depending upon its activity, severity of service, and environment, or as specifically indicated below. (These inspections shall include the requirements of 8.2.3):

- (1) Structural members for deformation, cracks or corrosion.
- (2) Parts, such as pins, bearings, shafts, gears, rollers, locking devices, chains, chain sprockets, wire and synthetic ropes and sheaves, for wear, cracks or distortion.
- (3) Hydraulic and pneumatic relief valve settings.
- (4) Hydraulic system for proper oil level.
- (5) Hydraulic and pneumatic fittings, hoses and tubing for evidence of leakage, abnormal deformation or excessive abrasion.
- (6) Compressors, pumps, motors and generators for loose fasteners, leaks, unusual noises or vibrations, loss of operating speed and excessive heating.
- (7) Hydraulic and pneumatic valves for malfunction and visible cracks in the external valve housing, for leaks and sticking spools.
- (8) Visually inspect any vacuum prevention systems and verify function of such systems on Category "A" aerial devices.
- (9) Hydraulic and pneumatic cylinders and holding valves for malfunction and visible damage.
- (10) Hydraulic and pneumatic filters for cleanliness and the presence of foreign material in the system indicating other component deterioration.
- (11) Electrical systems and components for deterioration or wear including those not readily visible on a frequent inspection.
- (12) Performance test of all boom movements.
- (13) Condition and tightness of bolts and other fasteners.
- (14) Welds, as specified by the manufacturer.
- (15) Legible and proper identification, operational and instructional markings.
- (16) If the aerial device is rated as an insulated device, the electrical insulating components and system(s) shall be thoroughly inspected for lack of cleanliness and other components that compromise insulation. Then these components and system(s) shall be tested for compliance with the rating of the aerial device in accordance with one of the applicable methods and procedures as outlined in Section 5.4.3 of this standard:
  - (a) If the aerial device is used for AC bare-hand work, the unit shall undergo a 60 Hz test as shown in Table 2 at least every three years;
  - (b) If the aerial device is used for DC bare-hand work, the unit shall undergo a DC test as shown in Table 2 at least every three years.
  - (c) After repair or modification of any component that crosses the insulating system(s), or the repair or replacement of an insulating component(s), the unit shall be dielectrically tested in accordance with section 5.4.3;
  - (d) An insulated replacement boom shall be tested to insure conformance to 5.3.3 by the supplier;
  - (e) Bare-hand work units shall be tested as shown in Table I after any major repair to the insulated boom or any insulated boom replacement. Any suspected items shall be carefully examined or tested and a determination made by a qualified person as to whether they constitute a safety hazard. All unsafe items shall be replaced or repaired before use.

- (1) Items to be inspected shall be designated to the operator or other authorized person making frequent inspections. Records of frequent inspections need not be made. However, where a safety hazard is found, it shall be reported in writing to a person responsible for the corrective action and that report and a record of the correction shall be maintained for five years, or as required by applicable regulations.
- (2) Written, dated and signed reports and records shall be made of periodic inspections and tests and retained for a period of five years or as required by applicable regulations.

**8.4.1.1 Maintenance.** Maintenance and frequency of maintenance shall be determined by the owner in accordance with the manufacturer's recommendations. Welding repairs of components or welds, designated as critical in the manufacturer's manual, shall be made in accordance with the manufacturer's recommendations. Should the original manufacturer no longer exist an equivalent entity may determine the required procedure.

**8.4.1.2 Maintenance Training.** The owner shall train their maintenance personnel in inspection and maintenance of the aerial device in accordance with the manufacturer's recommendations and Section 8 of this standard.

**8.4.1.3 Modifications.** No modifications or additions which affect the stability, mechanical, hydraulic, or electrical integrity or the safe operation of the aerial device shall be made without the written approval of the manufacturer. If such modifications or changes are made, the capacity, operation, and maintenance instruction markings shall be changed accordingly. In no case shall the safety factors be reduced below those specified in this standard or below the manufacturer's design safety factors, whichever are greater. Should the original manufacturer no longer exist, an equivalent entity may approve required modification.

**8.6 Weight Distribution.** Changes in loading or additions made to the mobile unit after the final acceptance that affect weight distribution shall meet applicable regulations by governmental agencies. In no case shall axle loads of the fully loaded vehicle exceed the Gross Axle Weight Ratings (GAWR) assigned by the manufacturer. Note: Any change in weight distribution may adversely affect stability.

**8.7 Transfer of Ownership.** When a change in ownership of an aerial device occurs, it shall be the responsibility of the seller to provide the manufacturer's manual(s) for that aerial device to the purchaser. It is the responsibility of the purchaser to notify the manufacturer of the unit model and serial number and the name and address of the new owner within 60 days.

**8.8 Markings.** The markings on the aerial device shall not be removed, defaced, or altered. All missing or illegible markings shall be promptly replaced.

**8.9 Parts.** When parts or components are replaced they shall be identical in specification and function to the original aerial device parts or components or shall provide an equal or greater factor of safety.

**8.10 Safety Bulletins.** Owners shall comply with safety related bulletins as received from the manufacturer, dealer or installer.

**8.11 Manuals.** The owner shall insure that the operating manual(s) is stored on the mobile unit.

**8.12 Training, Retraining, and Familiarization of Operators.**

**8.3 Inspection and Test Records.**

- 8.12.1 **Owner as a Renter or Lessor.** When an owner functions as a renter or lessor he shall have the same responsibilities as specified under Section 11 of this standard.
- 8.12.2 **General Training.** Only personnel who have received general instructions regarding the inspection, application and operation of aerial devices, including recognition and avoidance of hazards associated with their operation, shall operate an aerial device. Such items covered shall include, but not necessarily be limited to, the following issues and requirements:
- (1) The purpose and use of manuals.
  - (2) That operating manuals are an integral part of the aerial device and must be properly stored on the vehicle when not in use.
  - (3) A pre-start inspection.
  - (4) Responsibilities associated with problems or malfunctions affecting the operation of the aerial device.
  - (5) Factors affecting stability.
  - (6) The purpose of placards and decals.
  - (7) Workplace inspection.
  - (8) Applicable safety rules and regulations, such as Part 4, ANSI C2-1997, National Electrical Safety Code (applies to utility workers as defined in ANSI C2). The above standard is an example; other industries using aerial devices have safety rules pertinent to that industry.
  - (9) Authorization to operate.
  - (10) Operator warnings and instructions.
  - (11) Actual operation of the aerial device. Under the direction of a qualified person, the trainee shall operate the aerial device for a sufficient period of time to demonstrate proficiency in the actual operation of the aerial device.
  - (12) Proper use of personal fall protection equipment.
- 8.12.3 **Retraining.** The operator shall be retrained, when so directed by the user, based on the user's observation and evaluation of the operator.
- 8.12.4 **Familiarization.** When an operator is directed to operate an aerial device he/she is not familiar with, the operator, prior to operating, shall be instructed regarding the following items and issues:
- (1) The location of the manuals.
  - (2) The purpose and function of all controls.
  - (3) Safety devices and operating characteristics specific to the aerial device.
9. **Responsibility of Users.**
- 9.1 **General Responsibilities.** Each User shall comply with the requirements of this section.
- 9.2 **Personnel.** Only trained and authorized personnel shall be permitted to operate the aerial device.
- 9.3 **Training, Retraining, and Familiarization of Operators.**
- 9.3.1 **General Training.** Only personnel who have received general instructions regarding the inspection, application and operation of aerial devices, including recognition and avoidance of hazards associated with their operation, shall operate an aerial device. Such items covered shall include, but not necessarily be limited to, the following issues and requirements:
- (1) The purpose and use of manuals.
  - (2) That operating manuals are an integral part of the aerial device and must be properly stored on the vehicle when not in use.
  - (3) A pre-start inspection.
  - (4) Responsibilities associated with problems or malfunctions affecting the operation of the aerial device.
  - (5) Factors affecting stability.
  - (6) The purpose of placards and decals.
  - (7) Workplace inspection.
  - (8) Applicable safety rules and regulations, such as Part 4, ANSI C2-1997, National Electrical Safety Code. (Applies to utility workers as defined in ANSI C2). The above standard is an example; other industries using aerial devices have safety rules pertinent to that industry.
  - (9) Authorization to operate.
  - (10) Operator warnings and instructions.
  - (11) Actual operation of the aerial device. Under the direction of a qualified person, the trainee shall operate the aerial device for a sufficient period of time to demonstrate proficiency in the actual operation of the aerial device.
  - (12) Proper use of personal fall protection equipment.
- 9.3.2 **Retraining.** The operator shall be retrained, when so directed by the user, based on the user's observation and evaluation of the operator.
- 9.3.3 **Familiarization.** When an operator is directed to operate an aerial device he/she is not familiar with, the operator, prior to operating, shall be instructed regarding the following items and issues:
- (1) The location of the manuals.
  - (2) The purpose and function of all controls.
  - (3) Safety devices and operating characteristics specific to the aerial device.
- 9.4 **Application.** The employer and assigned operator shall insure that the aerial device is used only for intended applications as defined in the operating manual, and that recognized safety practices are observed.
- 9.5 **Mobile Operation.** Before and during driving, the driver shall:
- (1) Avoid traveling on any surface that adversely affects vehicle stability.
  - (2) Maintain a safe distance from obstacles and overhead lines.
  - (3) Maintain communications between the driver and the operator.
  - (4) Under all travel conditions, the driver shall limit travel speed in accordance with conditions of the ground surface, congestion, and slope.
- 9.6 **Alterations.** Altering or disabling of safety devices, guards, or interlocks if so equipped shall be prohibited.
- 9.7.1 **Bare-Hand Work.** For bare-hand work, a Category "A" aerial device shall be used.
- 9.8 **Lower Controls.** The lower controls of aerial devices shall not be used for continuous operation with personnel in the platform.
10. **Responsibilities of Operators**
- 10.1 **General Responsibilities.** Each operator shall comply with the requirements of this section.
- 10.2 **Operation.** During operation of the aerial device all platform occupants shall use appropriate fall protection connected to the aerial device at the platform position.
- 10.3 **Work Platform.** The operator shall not use railings, planks, ladders or any other device in or on the work platform for achieving additional working height or reach.

- 10.4 **Brakes.** The vehicle parking brake(s) shall be set at all times that the boom is elevated except when the aerial device is being used in accordance with 9.5.
- 10.5 **Loading.** Any loading which includes a horizontal load shall be avoided unless the mobile unit is designed for that application.
- 10.6 **Observations.** Observations during operation for any defects shall be conducted on an ongoing basis.
- 10.6.1 **Pre-start Inspection.** Items determined by the owner in accordance with the manufacturer's recommendations for each specific aerial device shall be inspected for defects prior to each day's operation. The following tests and inspections shall be performed by the operator once daily, prior to first use:
- (1) Operating controls and associated mechanisms for conditions interfering with proper operation.
  - (2) Visual and audible safety devices for malfunction.
  - (3) Hydraulic or pneumatic systems for observable deterioration or excessive leakage.
  - (4) Fiberglass and other insulating components for visible damage or contamination.
  - (5) Missing or illegible operational and instructional markings.
  - (6) Electrical systems of/or related to the aerial device for malfunction, signs of excessive deterioration, dirt and moisture accumulation.
  - (7) Visual inspection of bolts, pins, and other fasteners for loose, deformed or missing fasteners and other locking devices. Any suspected items shall be carefully examined or tested and a determination made by a qualified person as to whether they constitute a safety hazard. All unsafe items shall be replaced or repaired before use.
- 10.7 **Worksite.** Before the aerial device is used the worksite shall be surveyed for hazards such as:
- (1) Untamped earth fills.
  - (2) Ditches.
  - (3) Drop-offs and floor obstructions.
  - (4) Debris.
  - (5) Overhead obstructions and electrical conductors.
  - (6) Weather conditions.
  - (7) Presence of unauthorized persons.
- 10.8 **Precautions.** Before and during each use the operator shall:
- (1) Check for overhead obstructions and electrical conductors.
  - (2) Insure that the load on the platform and/or load lifting devices are in accordance with the manufacturer's rated capacity.
  - (3) Insure that outriggers and stabilizers are used if the manufacturer's instructions require their use.
  - (4) Insure that guardrails are properly installed, and the gates are closed.
  - (5) Use outrigger pads when necessary to provide firm footing.
- 10.9 **Mobile Operation.** Before engaging in mobile operation the operator shall determine that the aerial device is specifically designed for mobile operation.
- 10.10 **Personnel.** Only trained and authorized personnel shall be permitted to operate the aerial device.
- 10.11 **Training, Retraining, and Familiarization of Operators.**
- 10.11.1 **General Training.** Only personnel who have received general instructions regarding the inspection, application and operation of aerial devices, including recognition and avoidance of hazards associated with their operation, shall operate an aerial device. Such items covered shall include, but not necessarily be limited to, the following issues and requirements:
- (1) The purpose and use of manuals.
  - (2) That operating manuals are an integral part of the aerial device and must be properly stored on the vehicle when not in use.
  - (3) A pre-start inspection.
  - (4) Responsibilities associated with problems or malfunctions affecting the operation of the aerial device.
  - (5) Factors affecting stability.
  - (6) The purpose of placards and decals.
  - (7) Workplace inspection.
  - (8) Applicable safety rules and regulations, such as Part 4, ANSI C2-1997, National Electrical Safety Code (applies to utility workers as defined in ANSI C2). The above standard is an example; other industries using aerial devices have safety rules pertinent to that industry.
  - (9) Authorization to operate.
  - (10) Operator warnings and instructions.
  - (11) Actual operation of the aerial device. Under the direction of a qualified person, the trainee shall operate the aerial device for a sufficient period of time to demonstrate proficiency in the actual operation of the aerial device.
  - (12) Proper use of personal fall protection equipment.
- 10.11.2 **Retraining.** The operator shall be retrained, when so directed by the user, based on the user's observation and evaluation of the operator.
- 10.11.3 **Familiarization.** When an operator is directed to operate an aerial device he/she is not familiar with, the operator, prior to operating, shall be instructed regarding the following items and issues:
- (1) The location of the manuals.
  - (2) The purpose and function of all controls.
  - (3) Safety devices and operating characteristics specific to the aerial device.

### Responsibilities of Renters, Lessors or Lessees

- 11.1 **General Responsibilities.** Each renter or lessor or lessee shall comply with the requirements of the applicable section or sections below.
- 11.1.1 **Lessor or Lessee as Dealer or Installer.** When a lessor or lessee uses the aerial device as a dealer or installer he shall have the same responsibilities as specified under Section 7 of this standard.
- 11.1.2 **Lessor or Lessee as Owner.** When a lessor or lessee uses the aerial device as an owner he shall have the same responsibilities as specified under Section 8 of this standard.
- 11.1.3 **Lessor or Lessee as User.** When a lessor or lessee uses the aerial device as a user he shall have the same responsibilities as specified under Section 9 of this standard.
- 11.1.4 **Lessor or Lessee as Operator.** When a lessor or lessee uses the aerial device as an operator he shall have the same responsibilities as specified under Section 10 of this standard.
- 11.2 **Ownership Duties.** The renter or lessor shall carry out the duties of ownership specified in this standard which are not assigned to the renting entity or lessee as the user.

- 11.3 **Obligations.** Upon delivery each renter or lessor of an aerial device shall provide the operators manual and the ANSI/SIA A92.2-xxxx Manual of Responsibilities for dealers, owners, users, operators, lessors and lessees of Vehicle Mounted Elevating and Rotating Aerial Devices. These manuals shall be stored on the mobile unit.
- 11.4 **Training.** The renter or lessor shall offer training or training materials that aid the renting entity or lessee in the operation, inspection, testing and maintenance of the aerial device. This training shall be offered initially and subsequently on request.
- 11.4.1 **General Training.** Only personnel who have received general instructions regarding the inspection, application and operation of aerial devices, including recognition and avoidance of hazards associated with their operation, shall operate an aerial device. Such items covered shall include, but not necessarily be limited to, the following issues and requirements:
- (1) The purpose and use of manuals.
  - (2) That operating manuals are an integral part of the aerial device and must be properly stored on the vehicle when not in use.
  - (3) A pre-start inspection.
  - (4) Responsibilities associated with problems or malfunctions affecting the operation of the aerial device.
  - (5) Factors affecting stability.
  - (6) The purpose of placards and decals.
  - (7) Workplace inspection.
- (8) Applicable safety rules and regulations, such as Part 4, ANSI C2-1997, National Electrical Safety Code (applies to utility workers as defined in ANSI C2). The above standard is an example; other industries using aerial devices have safety rules pertinent to that industry.
- (9) Authorization to operate.
- (10) Operator warnings and instructions.
- (11) Actual operation of the aerial device. Under the direction of a qualified person, the trainee shall operate the aerial device for a sufficient period of time to demonstrate proficiency in the actual operation of the aerial device.
- (12) Proper use of personal fall protection equipment.
- 11.4.2 **Familiarization.** When an operator is directed to operate an aerial device he/she is not familiar with, the operator, prior to operating, shall be instructed regarding the following items and issues:
- (1) The location of the manuals.
  - (2) The purpose and function of all controls.
  - (4) Safety devices and operating characteristics specific to the aerial device.
- 11.5 **Communications.** In the event the manufacturer or installer provides the renter or lessor manuals, bulletins, or other materials for the information of the user of an aerial device, the renter or lessor shall pass them on to the user without any undue delay.

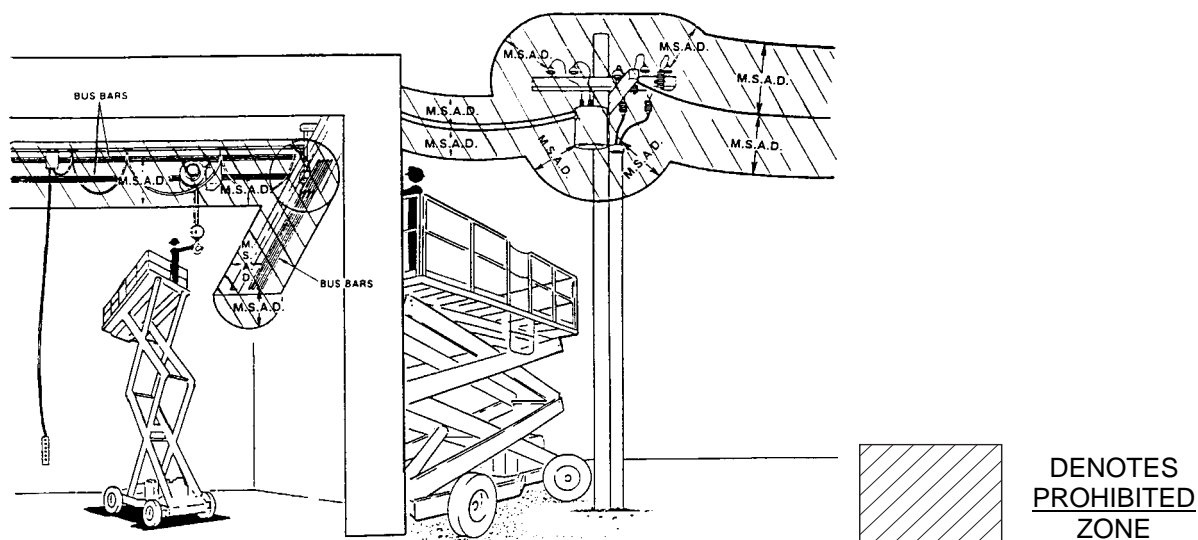

Figure 6-1. Minimum Safe Approach Distances

**⚡ DANGER**

Do not allow machine, personnel, or conductive materials inside prohibited zone. Maintain M.S.A.D. from all energized lines and parts as well as those shown. Assume all electrical parts and wires are energized unless known otherwise.

**⚠ CAUTION**

Diagrams shown are only for purposes of illustrating M.S.A.D. work positions, not all work positions.

Voltage Range	Minimum Safe Approach Distance	
	(Feet)	(Meters)
0 to 300V	Avoid Contact	
Over 300V to 50KV	10	3.05
Over 50KV to 200KV	15	4.60
Over 200KV to 350KV	20	6.10
Over 350KV to 500KV	25	7.62
Over 500KV to 750KV	35	10.67
Over 750KV to 1000KV	45	13.72

Minimum Safe Approach Distances



# 7 MATERIAL SAFETY

The following Material Safety Data Sheets describe the correct procedures for the safe handling of chemical components within the Model 3522A Telescoping Boom Lift, as well as any potential health and safety hazards related to these chemicals. Material Safety Data Sheets are included here in accordance with applicable federal and state regulations. Read and observe all safety precautions. Maintain awareness of potential health and safety hazards.

## MATERIAL SAFETY DATA SHEET FOR LEAD ACID BATTERIES, WET, FILLED WITH ACID

SECTION I – GENERAL INFORMATION					
Manufacturer's Name:	Crown Battery Mfg. Company	EMERGENCY NO: 800 487-2879			
Street Address:	1445 Majestic Drive	OR 800 OIL-TANK			
City, State, Zip	Fremont, Ohio 43420	REVISION DATE: 5/18/2000			
Phone Number:	419 334-7181				
SECTION II -- MATERIAL IDENTIFICATION AND INFORMATION					
COMPONENTS	PERCENT	OSHA PEL	ACGIH TLV	OTHER LIMITS	CAS NUMBER
Hazardous Components 1% or greater Carcinogens 0.01% or greater					
METALLIC LEAD METAL	25.5%	0.05 mg/m3	0.05 mg/m3	NONE	7439-92-1
LEAD SULFATES	18.2%	0.05 mg/m3	0.05 mg/m3	NONE	7439-92-1
LEAD OXIDES	18.0%	0.05 mg/m3	0.05 mg/m3	NONE	7439-92-1
POLYPROPYLENE CASE MTL	6.4%				
SEPARATORS	3.5%				
SULFURIC ACID (H2SO4)	5.2%	1.0 mg/m3	1.0 mg/m3	NONE	7664-93-9
WATER	19.2%				
REGULATORY INFORMATION:	Those ingredients listed above are not subject to the reporting requirements of 313 of Title III of the Superfund Amendments and Reauthorization Act. The items are covered in an exemption as a "Manufactured Article". 372.30(b)				
SECTION III -- PHYSICAL / CHEMICAL CHARACTERISTICS					
Boiling Point	Approximately 203F	Vapor Density:	Greater Than 1		
Vapor Pressure	14 @ 37% @ 80 F	Melting Point:	-36 F to -10.6 F		
Solubility in Water	100%	Water Reactive:	Yes, Produces Heat		
Specific Gravity	1.245 - 1.295 Battery Electrolyte				
Appearance & Odor	Clear Liquid with Sharp Pungent Odor				
SECTION IV -- FIRE AND EXPLOSION HAZARD DATA					
Flash Point:	Not Combustible				
Auto Ignition Temperature	N/A	Flammability Limits in Air % by Volume:	N/A		
Extinguishing Media:	Dry Chemical Carbon Dioxide, Water Fog, Water				
Special Fire Fighting Procedures:	Sulfuric Acid Fumes, Sulfur Dioxide Gas or Carbon Monoxide may be released when acid decomposes. Wear NIOSH approved self-contained breathing apparatus.				
Unusual Hazards:	Water applied to sulfuric acid generates heat and causes acid to splatter. Wear full-cover acid resistant clothing. Sulfuric acid reacts violently with metals, nitrates, chlorates, carbides, fulminates, picrates and other organic materials. Reacts with most metals to yield explosive/flammable hydrogen gas. This reaction is intensified when sulfuric acid is diluted with water to form battery electrolyte.				

**MATERIAL SAFETY DATA SHEET**

FOR LEAD ACID BATTERIES, WET, FILLED WITH ACID (Continued)

**SECTION V -- HEALTH HAZARD DATA**

Primary Routes of Entry:	Inhalation: YES Skin: YES Ingestion: YES
Health Hazards:	Acute EYES, SKIN, RESPIRATORY SYSTEM & DIGESTIVE SYSTEM Chronic: EYES, SKIN, RESPIRATORY SYSTEM & DIGESTIVE SYSTEM
Signs and Symptoms of Exposure:	IRRITATION OF EXPOSED AREA, BURNS AND RESPIRATORY PROBLEMS NO POSSIBILITY OF EXPOSURE OF LEAD WILL OCCUR UNLESS BATTERY IS DESTROYED.
Medical Conditions Generally Aggravated By Exposure:	EXPOSURE TO MIST MAY CAUSE LUNG DAMAGE & AGGRAVATE PULMONARY CONDITION.
Emergency First Aid Procedures:	SEEK MEDICAL ASSISTANCE FOR FURTHER TREATMENT, OBSERVATION AND SUPPORT IF NECESSARY.
Eye Contact:	WASH WITH COPIOUS QUANTITIES OF COOL WATER FOR AT LEAST 15 MINUTES
Skin Contact:	FLUSH AREA WITH LARGE AMOUNTS OF COOL WATER FOR AT LEAST 15 MINUTES
Inhalation:	REMOVE TO FRESH AIR, IF BREATHING IS DIFFICULT - GIVE OXYGEN
Ingestion:	GIVE MILK TO DRINK, <u>DO NOT</u> INDUCE VOMITING. CALL PHYSICIAN

**SECTION VI -- REACTIVITY DATA**

Stability:	STABLE	Conditions to Avoid: N/A
Incompatibility:	AVOID COMBUSTIBLES, ORGANIC MATERIALS, AND STRONG REDUCING AGENTS	
Hazardous Decomposition Products:	SULFUR TRIOXIDE, CARBON MONOXIDE, SULFURIC ACID FUMES, & SULFUR DIOXIDE	
Hazardous Polymerization:	MAY OCCUR	Conditions to Avoid: N/A

**SECTION VII -- SPILL OR LEAK PROCEDURES**

Steps to be taken in case material is released or spilled:  
CONTAIN SPILL, USING NON-COMBUSTIBLE MATERIALS: VERMICULITE, DRY SAND & EARTH. NEUTRALIZE  
WITH LIME, SODA ASH, SODIUM BICARBONATE, ETC.

Waste disposal method: CONSULT STATE ENVIRONMENTAL AGENCY. INDIVIDUAL STATE REGULATIONS VARY

Precautions to be taken in Handling & Storage: SEPARATE FROM INCOMPATIBLE MATERIALS, KEEP AWAY  
FROM FIRE, SPARKS AND HEAT

Other Precautions and/or Special Hazards:  
CONTACT WITH METALS MAY PRODUCE TOXIC SULFUR DIOXIDE FUMES & MAY ALSO RELEASE FLAMMABLE  
HYDROGEN GAS. THIS REACTION IS INTENSIFIED WHEN DILUTED.

NFPA Rating:	HEALTH: 3	FLAMMABILITY: 0	REACTIVITY: 2	SPECIAL: 0
HMIS Rating:	HEALTH: 3	FLAMMABILITY: 0	REACTIVITY: 2	PERSONAL PROTECTION: X

**SECTION VIII -- CONTROL AND PROTECTIVE MEASURES**

Respiratory Protection:	ABOVE P.E.L.: NIOSH APPROVED, FITTED, FULL FACE RESPIRATOR
Protective Gloves:	ACID RESISTANT
Eye Protection:	FULL FACE PROTECTION
Ventilation:	LOCAL EXHAUST: VENTILATED AREA PREFERRED MECHANICAL: IF BELOW P.E.L. SPECIAL: MUST BE ACID & EXPLOSIVE RESISTANT OTHER: MUST BE ACID & EXPLOSIVE RESISTANT
Other Protective Equipment:	ACID RESISTANT CLOTHING AND BOOTS
Hygienic Work Practices:	N/A

**MATERIAL SAFETY DATA SHEET**  
DEXRON III/MERCON AUTOMATIC TRANSMISSION FLUID (HYDRAULIC OIL)

SECTION I -- GENERAL INFORMATION	
TRADE NAME:	CITGO TRANSGARD™ ATF, DEXRON III/MERCON
EMERGENCY TELEPHONE NUMBERS:	918.495.4700 (medical); 800.424.9300 (chemical)
CHEMICAL FAMILY:	AUTOMATIC TRANSMISSION FLUID, LUBRICATING OIL
CAS NUMBER: MIXTURE.	REVISION DATE: 10/29/98
HAZARDOUS INGREDIENTS:	CONTAINS NO INGREDIENTS NOW KNOWN TO BE HAZARDOUS AS DEFINED IN OSHA 29 CFR 1910.1000 AND OSHA 29 CFR 1910.1200.
SECTION II -- HEALTH HAZARD DATA	
PRIMARY ROUTES OF ENTRY:	INHALATION, SKIN ABRASION AND INGESTION.
CARCINOGENIC:	NO
SYMPTOMS (INGESTION, CONTACT, INHALATION):	MILD, TRANSIENT SKIN OR EYE IRRITATION MAY OCCUR.
EYES:	FLUSH WITH WATER FOR 15 MINUTES
SKIN:	WASH THOROUGHLY WITH WARM SOAPY WATER.
INGESTION:	DO NOT INDUCE VOMITTING-SEEK MEDICAL ATTENTION.
CONDITIONS AGGRAVATED BY EXPOSURE:	NONE KNOWN
AIR EXPOSURE LIMITS: P.E.L. 5 mg/m3 (OSHA) T.L.V. 10mg/m3 (ACGIH)	
HEALTH: 0 FIRE: 1 SPECIFIC: X REACTIVITY: 0	
SECTION III -- PHYSICAL DATA	
BOILING POINT/FREEZING POINT:	N/A
VAPOR PRESSURE (PSIA):	N/A
SPECIFIC GRAVITY (H20=1):	0.86
SOLUBILITY IN WATER:	NEGLIGIBLE; INSOLUBLE IN COLD WATER
PH OF CONCENTRATE:	N/A
APPEARANCE AND ODOR:	RED LIQUID, MILD PETROLEUM ODOR
SECTION IV -- FIRE AND EXPLOSION HAZARD DATA	
FLASH POINT (METHOD USED):	CLOSED: 339° F (Pensky-Martens); OPEN: 390° F (Cleveland).
FLAMMABLE LIMITS:	NOT DETERMINED
LEL: N/A UEL: N/A	
EXTINGUISHING MEDIA:	DRY CHEMICAL, FOAM, CO2, WATER FOG. TREAT AS CLASS B FIRE.
UNUSUAL FIRE AND EXPLOSION HAZARDS:	PRODUCES COMBUSTIBLE VAPOR AT TEMPERATURES ABOVE FLASH POINT
SECTION V -- REACTIVITY DATA	
STABILITY:	STABLE
CONDITIONS TO AVOID:	AVOID EXTREMES OF HEAT; IGNITION SOURCES.
INCOMPATIBILITY (MATERIALS TO AVOID):	STRONG OXIDIZING MATERIALS.
HAZARDOUS DECOMPOSITION PRODUCTS:	INCOMPLETE COMBUSTION MAY CAUSE CARBON OXIDES.
HAZARDOUS POLYMERIZATION:	WILL NOT OCCUR.
SECTION VI -- SPECIAL PROTECTION INFORMATION	
RESPIRATORY PROTECTION (SPECIFIC TYPE):	NONE REQUIRED
VENTILATION:	NORMAL
LOCAL EXHAUST:	NORMAL
MECHANICAL EXHAUST (GENERAL):	X
PROTECTIVE GLOVES:	OIL IMPERVIOUS GLOVES RECOMMENDED
EYE PROTECTION:	SAFETY GLASSES RECOMMENDED
OTHER PROTECTIVE EQUIPMENT:	PROTECTIVE CLOTHING RECOMMENDED
SPECIAL LABELLING INSTRUCTIONS:	NOT REQUIRED
SPECIAL PACKAGING RECOMMENDATIONS:	NONE
HANDLING AND STORAGE RECOMMENDATIONS:	AVOID EXTREMES OF COLD OR HEAT. STORE IN CLEAN DRY AREA.
SPILL OR LEAK PROCEDURES:	IN CASE OF LEAK OR SPILL, DIKE AND ABSORB WITH INERT MATERIAL. FOLLOW ALL LOCAL, STATE AND FEDERAL REGULATIONS FOR DISPOSAL.
<p><b>DISCLAIMER:</b> THE INFORMATION CONTAINED HEREIN HAS BEEN COMPILED FROM SOURCES CONSIDERED TO BE DEPENDABLE AND IS ACCURATE TO THE BEST OF THE SELLER'S KNOWLEDGE. THE SELLER MAKES NO WARRANTY WHATSOEVER, EXPRESSED OR IMPLIED, REGARDING THE ACCURACY OF SUCH DATA OR THE RESULTS TO BE OBTAINED FROM THE USE THEREOF.</p>	



# 8 EQUIPMENT OPTIONS

---

The Bil-Jax lift may be equipped with one or more optional components designed for the convenience and safety of operators when using the equipment to accomplish specific tasks.

Always use only those components manufactured and/or authorized by Bil-Jax, Inc. Never make any adjustments or modifications or otherwise alter the equipment in any way that is not expressly recommended by the manufacturer.

When operating a machine equipped with optional components, observe all safety precautions set forth by the manufacturer, as well as all government codes and regulations regarding this equipment and its components.

Consult rental agency or equipment manufacturer regarding which optional components may be installed on the boom lift. For questions regarding safe use, contact your regional Bil-Jax dealer before attempting operation

## MATERIAL LIFTING HOOK

If the boom lift is equipped with a material lifting hook, observe the following procedure for material lift operation:

- ❑ Remove platform controls from the work platform by releasing the latch on the back of the platform control box.
- ❑ Disconnect platform control box from the load sense module located on the boom lift bulkhead.
- ❑ Remove the electric loopback plug from the receptacle on the bottom right of the ground control panel (Figure 8-1) and insert the platform control cable into the open receptacle.

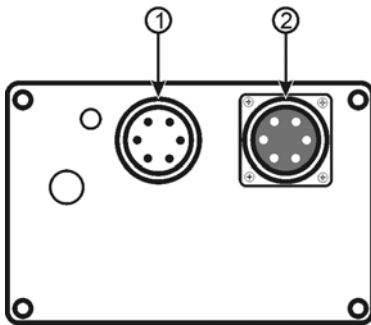

### 1. To Boom Cable.

Do Not Remove.

### 2. To Platform Controls.

Disconnect Platform controls from Load Sense Module here. Replace with loopback plug from ground control station. Plug platform controls into open receptacle on ground control station to operate Material Lifting Hook.

### Figure 8-1. Material Lifting Hook Configuration

- ❑ Insert the removed electric loopback plug into the open receptacle on the load sense module, replacing the platform control cable.
- ❑ Remove the retaining pin holding the platform to boom lift. Firmly secure platform to prevent equipment damage.
- ❑ Remove the platform from the boom by lifting cage up and away from the mounting bracket on the boom nose.
- ❑ Attach the material lifting hook to the mounting bracket on the boom nose and insert the retaining pin (Figure 8-2).

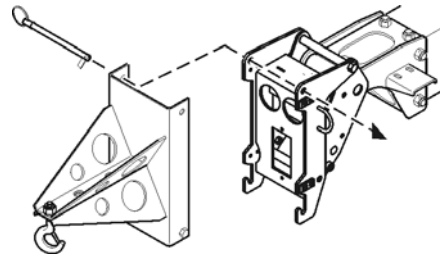

**Figure 8-2. Material Lifting Hook Installation**

- ❑ Operate the material lifting hook remotely, using the platform control box for optimal control.

### **! WARNING**

Always observe the manufacturer's weight lifting limitations when using the material lifting hook. Always use lifting straps or wire rope slings that are rated at a minimum 500 lbs lifting capacity. Never stand beneath an elevated load or position an elevated load above personnel. Falling objects can cause serious injury or death.

### **⚡ DANGER**

This machine is not insulated for use near electrical power lines and DOES NOT provide protection from contact with or close proximity to any electrically charged conductor. Operator must maintain safe clearances at all times and always allow for platform movement such as wind-induced sway. Refer to Table 1-1 for minimum safe approach distances between the machine and electrical power lines.

- ❑ Reverse the procedure to reattach the work platform.

## PLATFORM ROTATOR

The optional platform rotator allows the operator to rotate the elevated work platform 90° around a vertical axis by actuating a rotator handle found below the platform control panel.

To operate manual platform rotator, turn the rotator handle in the direction of desired rotation (clockwise or counterclockwise). Motion continues in the desired direction until rotator handle is released or the platform reaches a safe travel limit.

### **⚠ WARNING**

**Installation of a manual platform rotator may reduce the rated load limit of the work platform. Follow all manufacturer's recommendations and safety precautions when operating a boom lift equipped for platform rotation.**

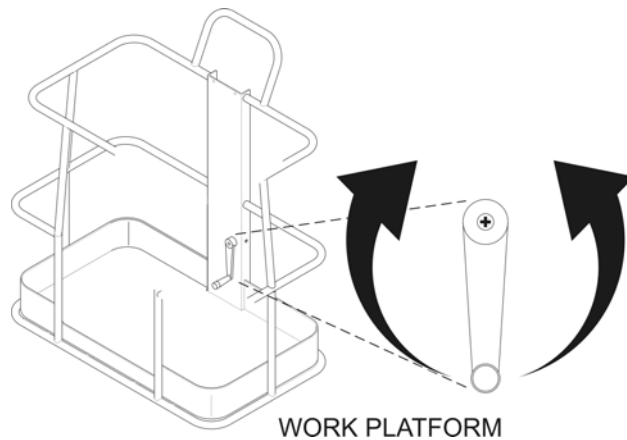

**Figure 8-3. Manual Platform Rotator**

## DRIVE AND SET

Use the following procedure to operate a boom lift equipped with the Drive and Set option:

Set parking brake. Drive function will not operate unless parking brake is set.

Lower jack stand and unhitch lift from tow vehicle.

If unit is equipped with a jockey wheel, remove lock pin and swing jockey wheel into lowered position. Reinsert lock pin to secure jockey wheel in lowered (drive) position (See Figure 8-4).

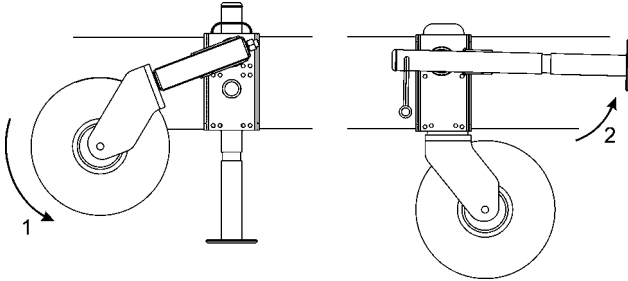

**Figure 8-4. Jockey Wheel Instruction**

Raise jack stand and swing into stowed position.

Completely lower platform. Drive function will not operate unless platform is completely lowered and fully stowed.

Fully retract outriggers.

Press and hold the DRIVE ENABLE button. Move joystick in the desired direction.

Machine will continue in the desired direction until joystick or drive enable button is released.

To resume platform operation, lower outriggers and level the lift using either the ground or platform controls and following the instructions found in Section 3 of this manual. Boom functions are not available until outriggers are fully deployed and machine is level.

## DRIVE AND SET SAFETY

NEVER drive machine unless parking brake is set.

NEVER drive machine without platform fully lowered or without operator securely inside the platform.

ALWAYS watch for personnel and obstructions in the path of the machine. Be aware of limited visibility and blind spots.

## DRIVE AND SET CONTROLS

The platform control station is used to control boom motion and drive and set functions, including outrigger deployment. To access the platform control station, turn the key switch at the ground control station to the platform controls setting and enter the work cage.

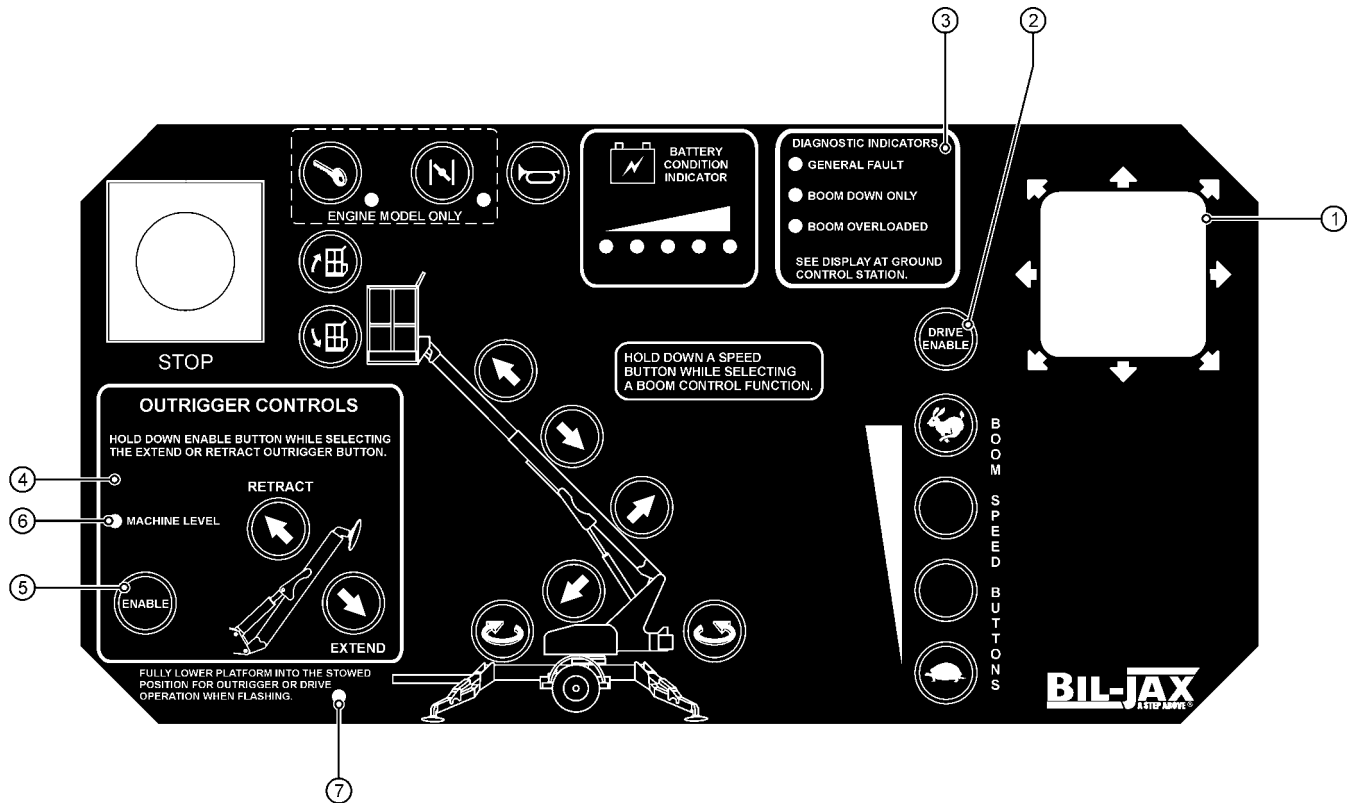

Figure 8-5. Drive and Set Controls

3. Drive and Set Joystick
4. Drive Enable Button
5. Diagnostic Indicators
6. Outrigger Controls
7. Outrigger Enable Button
8. Machine Level Indicator
9. Platform Position LED

The platform control station of a Drive and Set equipped machine includes the following controls and indicators. Refer to Figure 8-5 for locations.

**1. Drive and Set Joystick.**

Move the joystick in the desired direction while pressing and holding the DRIVE ENABLE (2) button to drive the fully retracted boom lift.

**2. Drive Enable Button.**

Press and hold the DRIVE ENABLE button while using the joystick (1) to drive the fully retracted boom lift. Release the DRIVE ENABLE button or joystick to stop.

**3. Diagnostic Indicators.**

Diagnostic Indicator LEDs will light to indicate an error in boom lift or drive function. When lit, check the display panel on the ground control station and the ERROR CODE DEFINITIONS chart in Section 4 of this manual.

**4. Outrigger Controls.**

Outriggers can be deployed from either the ground or platform control station on drive and set machines.

**5. Outrigger Enable Button.**

Press and hold the ENABLE button and the outrigger EXTEND or RETRACT button to deploy or retract outriggers.

**6. Machine Level Indicator.**

Indicator LED will light to indicate that the machine is level and boom functions can be performed.

**7. Platform Position LED.**

When flashing, boom must be fully stowed before resuming outrigger control or Drive and Set operations.

## REPLACEMENT DECALS

Refer to Table 8-1 and Figure 8-6 to Figure 8-7 for a descriptions and locations of replacement decals for optional components. Refer to Section 5 for a comprehensive list of standard decals on the Bil-Jax Model 3522A Telescoping Boom Lift.

All decals related to optional equipment have a quantity of one (1) unless otherwise noted.

**Table 8-1. Replacement Decals**

Decal No.	Description of Decal
B06-00-0474	NOTICE: Max. Load (All Configurations)
B06-00-0485	NOTICE: Material/Lifting Configuration Set-Up (Material Lift Option Only)
B06-00-0497	NOTICE: Load Capacity for Material Lifting Hook (Material Lift Option Only)
B06-00-0527	WARNING: Drive and Set Hazards
B06-00-0528	NOTICE: Drive and Set Instruction
B06-00-0529	NOTICE: Manual Platform Rotation (Manual Rotation Option Only)
B06-00-0553	WARNING: Jockey Wheel

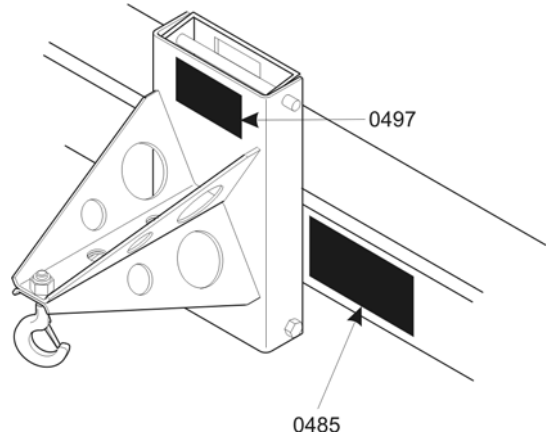

**Figure 8-6. Material Lift Decal Placement**

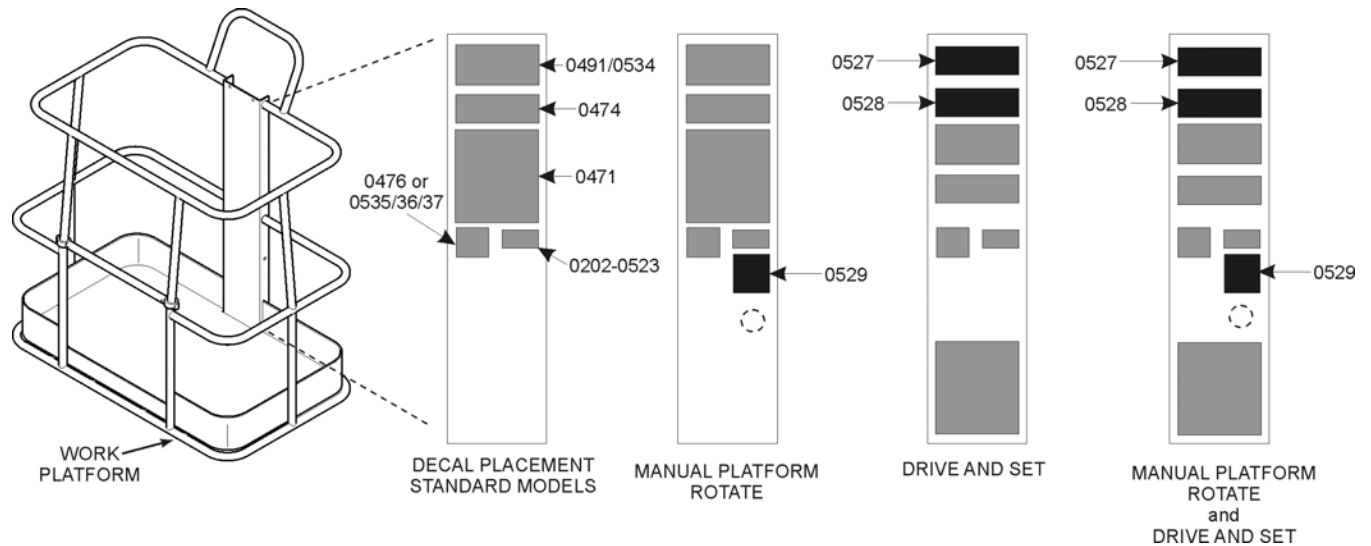

**Figure 8-7. Decal Locations**

## DAILY SERVICE CHECKS

Use the following checklist to record all daily checks made to the equipment. See Section 4 for a comprehensive list of service procedures.

Copy as necessary and keep with the machine at all times.

DATE \_\_\_\_\_

Verify that all Decals are properly affixed to machine.

Verify proper operation of all functions from ground and platform control stations.

Verify proper operation of all down limit switches and outrigger position switches.

Check hydraulic oil. Add fluid as necessary.

Check tires for proper inflation.

Verify proper operation of brake lights and running lights.

## WEEKLY SERVICE CHECKS

Use the following checklist to record all weekly checks made to the equipment. See Section 4 for a comprehensive list of service procedures.

Copy as necessary and keep with the machine at all times.

DATE \_\_\_\_\_

Check battery electrolyte level.

Check transport hitch components for damage and proper operation.

Check electrical wiring for cuts, loose wires or damage. Repair as necessary.

Check boom lift for loose or missing hardware. Replace or repair as necessary

## MONTHLY SERVICE CHECKS

Use the following checklist to record all monthly checks made to the equipment. See Section 4 for a comprehensive list of service procedures.

Copy as necessary and keep with the machine at all times.

DATE \_\_\_\_\_

Clean all battery terminals.

Check Battery for loose connections or damaged wires.

Verify proper operation of manual lowering valves and hand pump.

Lubricate all compartment hinges and latches, slew ring and mating gear.

Check wheel nut torque.

Use the following space to record and date any additional service checks, maintenance or alterations to machine. Attach any applicable certifications to this manual and keep with the machine at all times.

Always follow manufacturer's recommendations when repairing or maintaining the boom lift.

**Bil-Jax, Inc.**

125 Taylor Parkway  
Archbold, Ohio 43502  
800-537-0540

**REPORTING SAFETY DEFECTS**

If you believe that your vehicle has a defect that could cause a crash or could cause injury or death, you should immediately inform the National Highway Traffic Safety Administration (NHTSA) in addition to notifying Bil-Jax, Inc.

If the NHTSA receives similar complaints, it may open an investigation, and if it finds that a safety defect exists in a group of vehicles, it may order a recall and remedy campaign. However, the NHTSA cannot become involved in any individual problems between operators, users, or lessors, and Bil-Jax, Inc.

To contact the NHTSA you may either call the Auto Safety Hotline toll-free at 800-424-9393 (366-0123 in the Washington, DC area) or write to:

NHTSA  
U.S. DEPARTMENT of TRANSPORTATION  
400 7th Street SW (NSA-11)  
Washington, DC 20590

You can also obtain other information regarding motor vehicle safety by calling the Hotline.





